



ORMAT®

**PUNA GEOTHERMAL VENTURE
DRILLING PROGRAM**

GEOHERMAL WELL KS-19

June 12, 2020

PUNA GEOTHERMAL VENTURE (PGV)
P.O. Box 30
14-3860 Kapoho Pahoa Road
Pahoa, Hawaii 96778-0030
(808) 965-6233



APPLICATION FOR PERMIT TO DRILL GEOTHERMAL WELL KAPOHO STATE 19 (KS-19) ON RESERVED LANDS, KAPOHO, PUNA HAWAII

In compliance with the Hawaii Department of Land and Natural Resources (DLNR) Administrative Rule, Title 13, Chapter 183, Section 65, Puna Geothermal Venture (PGV) is herein applying to the Hawaii Board of Land and Natural Resources for a **Permit to Drill** a new geothermal well designated as **Kapoho State 19 (KS-19)**.

PGV proposes to: (1) directionally drill KS-19 to a total depth (TD) of approximately 4686 feet (ft); (2) measure the well’s temperature profiles; (3) perform a water loss test to determine permeability; and (4) based on temperature and permeability, make a determination for the well to either be a production or a reinjection well.

1. **Applicant:**

Puna Geothermal Venture
P.O. Box 30
14-3860 Kapoho Paho Road
Paho, Hawaii 96778-0030
(808) 965-6233

PUNA GEOTHERMAL VENTURE (PGV)

By: _____
Jordan Hara
Plant Manager
Puna Geothermal Venture

2. **Owner of Mining Rights:** State of Hawaii. A multi-well drilling bond (\$250,000) has previously been filed with the State of Hawaii.

3. **Land Owner:** Kapoho Land and Development Company, Limited

4. **Proposed Well Designation:** Kapoho State 19 (KS-19) off Wellpad E. Figures provided below include:

- A Tax Key map, showing the approximate location of the KS-19 drill site off Well pad E located on State Geothermal Mining Lease R-2;
- A topographic map, showing the approximate surface elevation at Well pad E of 619 feet above mean sea level; and
- A PGV Project map, designating the relative locations of KS-19 and Well pad E.

The proposed PGV geothermal well KS-19 will be drilled to a depth of approximately 4686 feet true vertical depth (TVD). The well will not approach closer than 100 feet from the vertical boundary line of the leased property. Depending on the permeability and temperature at the planned TVD, the well will then be designated for production or reinjection. A production well would provide additional production capacity and a reinjection well would be used for the processing of geothermal fluids and gases. The



development of either production or reinjection wells are permitted under the Plan-of-Operation approved March 10, 1989, by the Board of Land and Natural Resources.

5. **Compliance:** Puna Geothermal Venture agrees to perform such drilling activities as outlined in this application and agrees to maintain the well in accordance with Title 13, Chapter 183, State of Hawaii, and all Federal and County geothermal regulations and meet requirements in the Plan of Operations.

6. **General Information**

- | | | |
|----|--------------------------------|--|
| a. | Well Designation: | Kapoho State 19 (KS-19) |
| b. | Location: | TMK 1-04-01:19 |
| | Kapoho, Puna, Hawaii | (Figure 1) |
| c. | State Geothermal Mining Lease: | R-2 |
| d. | Owner of Mineral Rights: | State of Hawaii |
| e. | Subleased to: | Puna Geothermal Venture |
| f. | Operator: | PGV (affiliate of Ormat Nevada Inc., ONI). |

7. **Well Data**

- | | | |
|----|-----------------------|------------------|
| a. | Well Site: | Well Pad E |
| b. | Well map coordinates: | 154°53'27.01"W |
| | | 19°28'33.17"N |
| c. | Well Type: | Development Well |
| d. | Surface Elevation: | 619 feet AMSL |
| e. | Total Depth (TD): | 4686 feet |



DRILLING PROGRAM

PUNA GEOTHERMAL VENTURE (PGV)

GEOTHERMAL WELL KS-19

1 PROJECT DESCRIPTION

This section summarizes the drilling, well construction and environmental protection programs. Figures follow this section. See the following Appendices for additional project details:

- Appendix A: Detailed Drilling Procedures
- Appendix B: Directional Drilling Plan
- Appendix C: Mud Program
- Appendix D: Casing Design and Safety Factors
- Appendix E: Cementing Program
- Appendix F: Emergency Plans and Contacts
- Appendix G: Blowout Prevention and Action Plans
- Appendix H: Welding Procedures
- Appendix I: Rig Safety Inspection Form
- Appendix J: Reporting Criteria
- Appendix K: DLNR Formation Integrity Test (FIT)

1.1 Introduction and Location

Puna Geothermal Venture (PGV) proposes to conduct a geothermal well drilling program on leased lands at the Puna geothermal power plant facility. The purpose of the drilling program is to locate, drill, complete, test, and ultimately, to make a determination whether the geothermal well will be utilized as a production well or a reinjection well. The general location of the well is shown on Figure 1. The actual location will be surveyed after installation.

1.2 Proposed Well Site and Access Roads

The proposed well site is located on fee land leased by PGV in the Puna geothermal field. The actual location will be surveyed after the 30-in. conductor is cemented. As shown in Figure 1, the well site is located on an existing well pad that contains multiple other wells, so only very limited new surface disturbance will be required:

1. Clearing: At the selected site, the existing pad will be graded and leveled, as needed.
2. Earthwork: No cut and fill slopes will be required.
3. Drainage: The site will be graded to direct runoff from the pad into the cellar which will be pumped to the containment basin. Therefore, incidental or accidental uncontrolled spills of oil, fuel, and drilling fluids will be prevented from leaving the site.
4. Containment Basin: Exists on the pad. Drill mud and cuttings will be temporarily stored in this basin.



5. Well Sites Access: The access road to the well site will be improved if necessary.
6. Water: Water will be used for site construction, dust control and drilling. Water will be obtained from the on-site water well.

1.3 Drilling Process

Figure 2 depicts the proposed well design. For this program, PGV proposes to: (1) directionally drill the new well to a total measured depth of approximately ± 4686 feet (ft); (2) measure the well's temperature profiles; (3) measure the wells permeability; and (4) utilize the well as a production or reinjection well. If the well is unsuccessful as a producer or injector, it will be redrilled to an alternative target. PGV anticipates drilling to commence as soon as the rig is available to move onto the location.

The subsurface geology is anticipated to consist of the following units:

<u>Depth (MD):</u>	<u>Formation:</u>
0 - 620 ft.	Unsaturated subaerial basalt flows and intercalated cinder scoria.
620 ft. GL	Water Table
620 - 3000 ft.	Saturated subaerial basalt flows and intercalated cinder scoria; rare dikes.
3000 - 4000 ft.	Interbedded hyaloclastite deposits and minor subaerial grading into submarine basalt flows; localized dike swarms.
4000 - 6500 ft.	Submarine basalt flows cross-cut by basalt dikes and possibly high-permeability, near-vertical fractures, especially after 5500 ft.

The hole will be drilled with a normal rotary drilling rig such as those previously used in the Puna field. The rig will be equipped with diesel engines, storage tanks, mud pumps, and other typical auxiliary equipment. During drilling, the top of the derrick will be approximately 175 ft above ground level.

A gel, or gel and polymer, drilling fluid (drill mud) will circulate in the well bore to bring rock cuttings to the surface. The cuttings are separated and captured in the containment basin and the mud is recirculated. See Appendix C for mud program details.

Prior to drilling, the conductor will be installed by a separate drilling rig. The drilling rig will then be brought in and positioned over the conductor, and a 26-in. hole will be drilled to approximately **1050 ft KB** (see Appendix A for drilling details). Casing (22-in.) will be cemented in place and blowout prevention equipment (BOPE) will be installed. After testing the BOPE, a 20-in. hole will be drilled to approximately **2200 ft KB** and 16-in. casing containing a swell packer will be cemented in place. Following installation and testing of the BOPE, a 14-3/4-in. hole will be drilled to a total depth of approximately **3200 ft KB**. An 11-7/8-in. casing string will be run from surface to approximately **3200 ft** and cemented in place. A 10-1/2-in. hole will then be drilled to **± 4686 ft KB (TD)**. A Geothermal water loss test will be performed to assess permeability. Once permeability is confirmed acceptable, an 8-5/8-in. perforated liner will be hung from **± 3100 ft KB** to near bottom. If the well is designated as a producer, the rig will be rigged down and released for other work. If the well is designated to be an injector, a 9-5/8-in. hang down liner will be

run from the surface to ± 3000 ft KB. Then, the rig will be rigged down and released for other work.

NOTE: #13-183-76(b): All casing strings shall be pressure tested after cementing and before commencing any other operations on the well. Minimum casing test pressure shall be approximately one-third of the manufacturer's rated internal yield pressure; provided that the test pressure shall not be less than six hundred pounds per square inch and not greater than 1500 pounds per square inch. In cases where combination strings are involved, the above test pressures shall apply to the lowest pressure-rated casing used. Test pressures shall be applied for a period of thirty minutes. If a drop of more than ten percent of the test pressure should occur, the casing or cement job shall be considered defective and corrective measures shall be taken before commencing any further operations on the well.

1.4 Blowout Prevention Equipment (BOPE)

A 21-1/4-in. 2M API diverter stack with annular preventer and flow tee (banjo box) will be used below ± 1050 ft to ± 2200 ft (Figure 3). A 16-3/4-in. 5M double gate with pipe and blind rams along with an annular preventer and rotating head will be used below ± 2200 ft to total depth (see Figure 4 and Figure 5).

1.5 Personnel Requirements

Approximately 9 to 18 workers will be on location at any given time. The drilling crews will not be living on location.

PGV agrees to provide one (1) experienced Staff geologist full-time at any hydrologic change or prior to 2200 ft under the following conditions:

- PGV shall provide Mud Loggers who have experience mud logging in Hawaii.
- PGV shall provide a geologist full-time (defined as an 8-hour working day plus on call for 24 hours/day).

1.6 Abandonment Program

When required, the hole will be abandoned as directed by the regulatory agencies.

2 PROTECTION OF THE ENVIRONMENT

All PGV and drilling contractor personnel will be informed of PGV's policy regarding undue degradation of the environment. These measures are intended to prevent all unacceptable impacts from occurring as a result of these drilling operations.

2.1 Fire Prevention

The well site and access road will be cleared of all vegetation. The cleared area will be maintained during drilling operations. Fire extinguishers will be available on the sites and around the drilling rig. Water that is used for drilling will also be available for firefighting.

Personnel will be allowed to smoke only in designated areas. Any special permits required for welding and etc., will be applied for.

2.2 Prevention of Soil Erosion

Minimal soil erosion is anticipated because the existing well pad site is flat. Cut and fill slopes have been minimized near the well pad and plant site. Where needed, runoff will be channeled to energy dissipaters to minimize erosion.

2.3 Surface and Ground Water Quality Protection

The site has been designed to minimize the potential for surface water pollution from runoff during construction, drilling, and testing. Only non-toxic, non-hazardous drilling mud will be utilized during drilling operations. Drilling mud and drill cuttings will be stored in the lined containment basin. Any runoff from the surface will also be directed into the containment basin.

Impacts to both surface water and shallow ground water (the water table is expected at 620 ft bgs) will be prevented by the well's design, which includes installation of cemented steel casing strings through and below these zones. This cemented casing will prevent interzonal migrations of fluids and reduce the possibility of blowouts. Based on the water levels observed at the Puna production and Geothermal wells, no over-pressured or gas-rich zones are expected to be above 2750 ft. Below 2750 ft, pressures encountered may be as high as 1600 psig.

NOTE: When drilling a new well, upon drilling to a depth of the ground water, (usually at sea level), a representative sample of the ground water will be taken and analyzed. The results will be reported to the DLNR.

2.4 Air Quality Protection

Fugitive dust generation during construction and use of access road and well site will be minimized by watering as necessary. PGV will comply with any requirements concerning emissions of air pollutants from drilling equipment and non-condensable gases from the geothermal fluid during flow testing.

To limit NO_x emissions to less than 250 pounds per day, the total diesel fuel consumption will not exceed an average of 1200 gallons per day. Discharge of hydrogen sulfide (H₂S)

into the atmosphere will not exceed 2.5 kilograms per hour. If H₂S emissions exceed this limit, abatement equipment and technology will be utilized.

2.5 Noise Prevention

To abate noise pollution, mufflers will be utilized on engine-driven equipment and a sound wall will be constructed around the rig.

2.6 Protection of Public Health and Safety

In addition to the emergency contingency plans (see Appendix F), public health and safety will be protected through instructions to work crews and contractors regarding compliance with regulations.

2.7 Protection of Fish, Wildlife, and Botanical Resources

Direct impacts to wildlife habitat and botanical resources will be limited because the well site is an existing pad. Fish habitats are not anticipated to be affected as there are no fish in the existing pad or adjacent areas. However, prevention of erosion will be implemented.

2.8 Protection of Cultural Resources

The drilling site will be monitored for cultural resources. None are expected.

2.9 Waste Disposal

A containment basin is located on the drilling pad and all used mud and cuttings will be contained in this basin. After drilling operations are complete, the mud and associated drilling liquids will be allowed to evaporate.

Solid waste materials (trash) will be deposited at an authorized landfill by a disposal contractor. Portable chemical sanitary facilities will be used by all personnel. These facilities will be maintained by a local contractor.

2.10 Environmental Monitoring

Regular, routine visual inspections of the drill site and access road will be conducted by the on-site operational personnel, and/or the Puna Environmental Specialist, to quickly detect and correct any operational problems that could lead to environmental problems. The drilling fluid and cuttings will be monitored by visual inspection and chemical analyses by the drilling personnel, the well-site geologist, and the contract mud engineer to detect any problems which may be occurring downhole.

FIGURES

Figure 1. Well Location Map

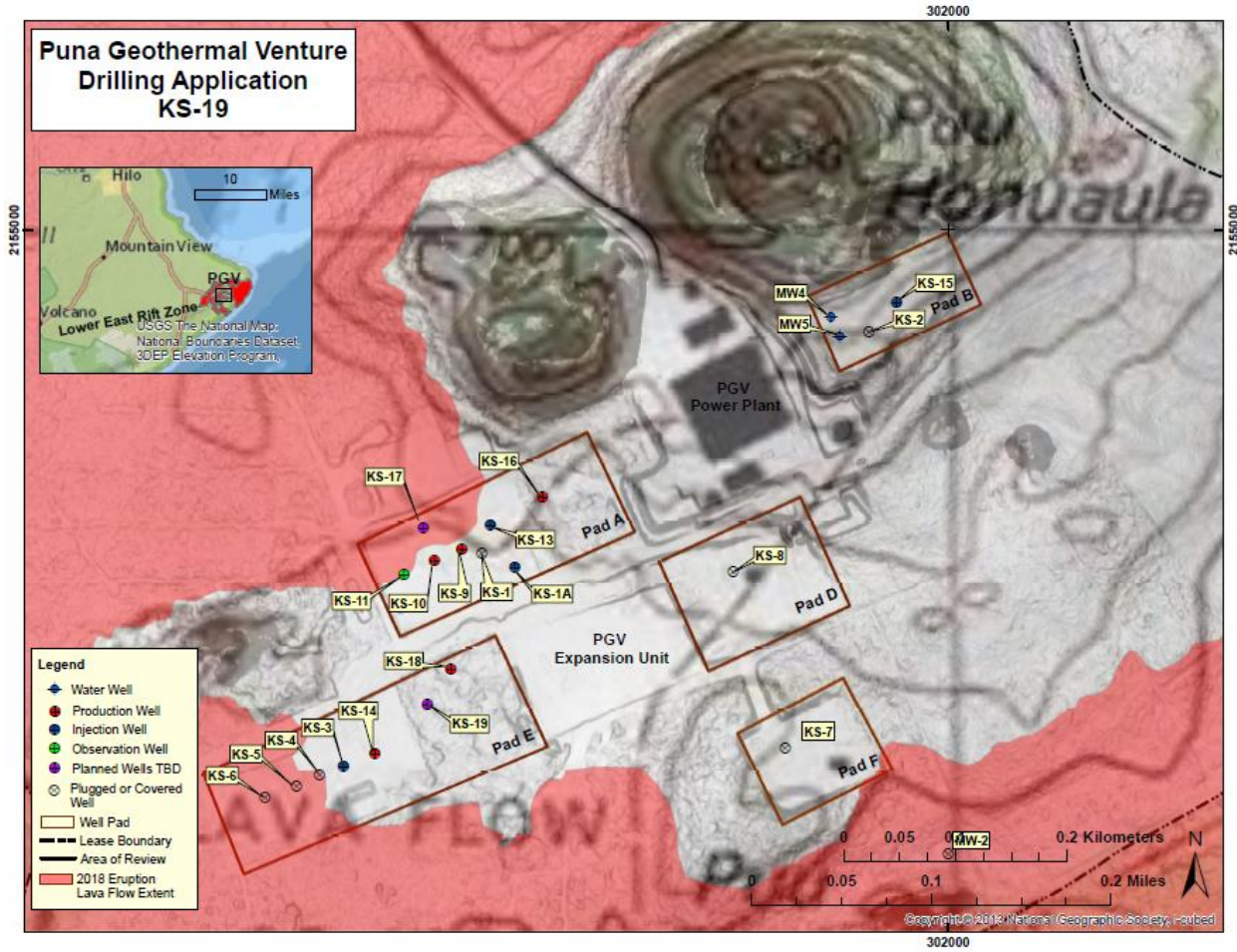

PGV Kapoho State KS-19

Hawaii County Puna District
Kilauea Rift Zone

Location: 19deg 28' 33.17"N Lat & 154deg 53' 27.01" W Long

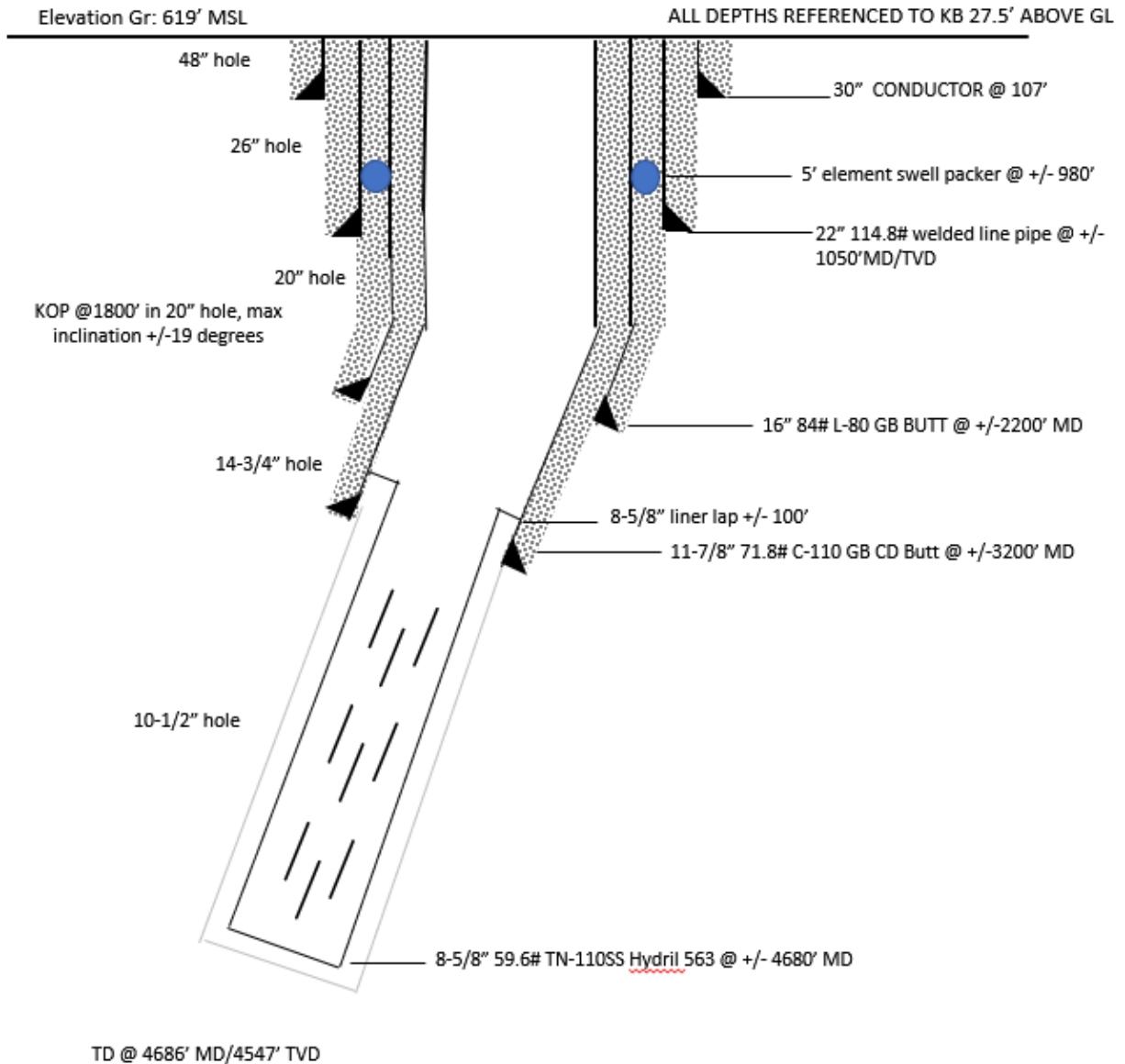

Figure 2. Well Construction Schematic.

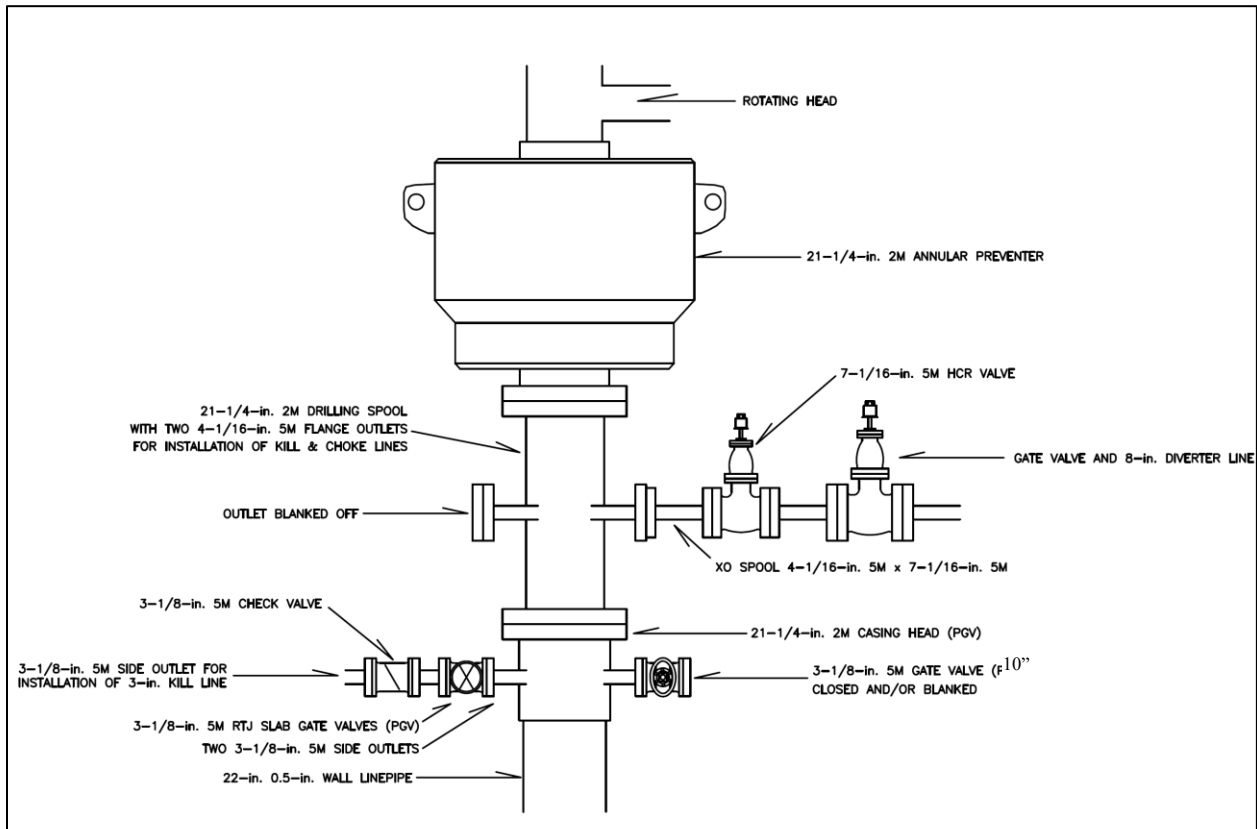

Figure 3. 21.25-inch BOPE for 22-inch casing while drilling 20-inch hole.

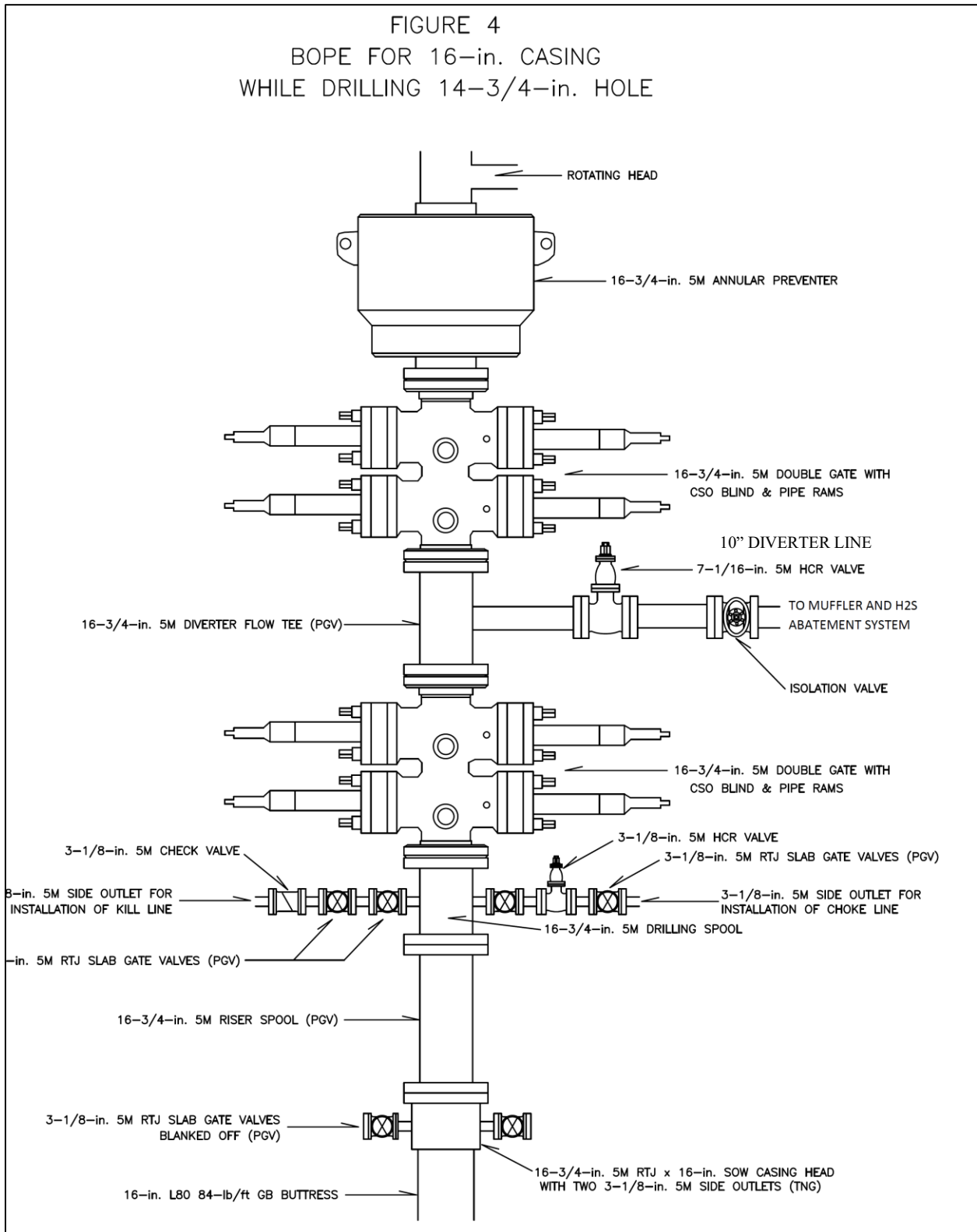

Figure 4. BOPE for 16-inch casing while drilling 14-3/4-inch hole.

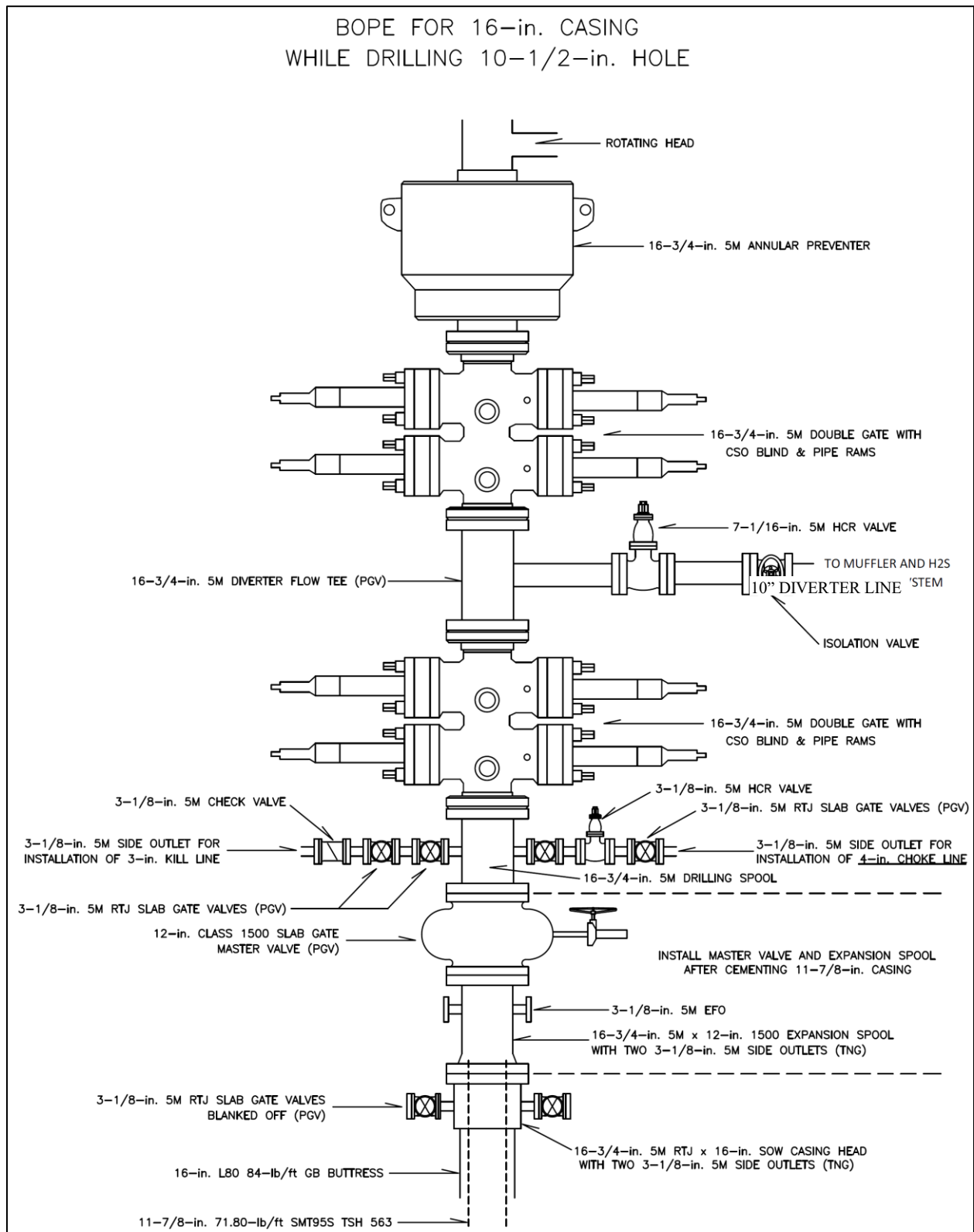

Figure 5. BOPE for 16-inch casing while drilling 10-1/2-inch hole.

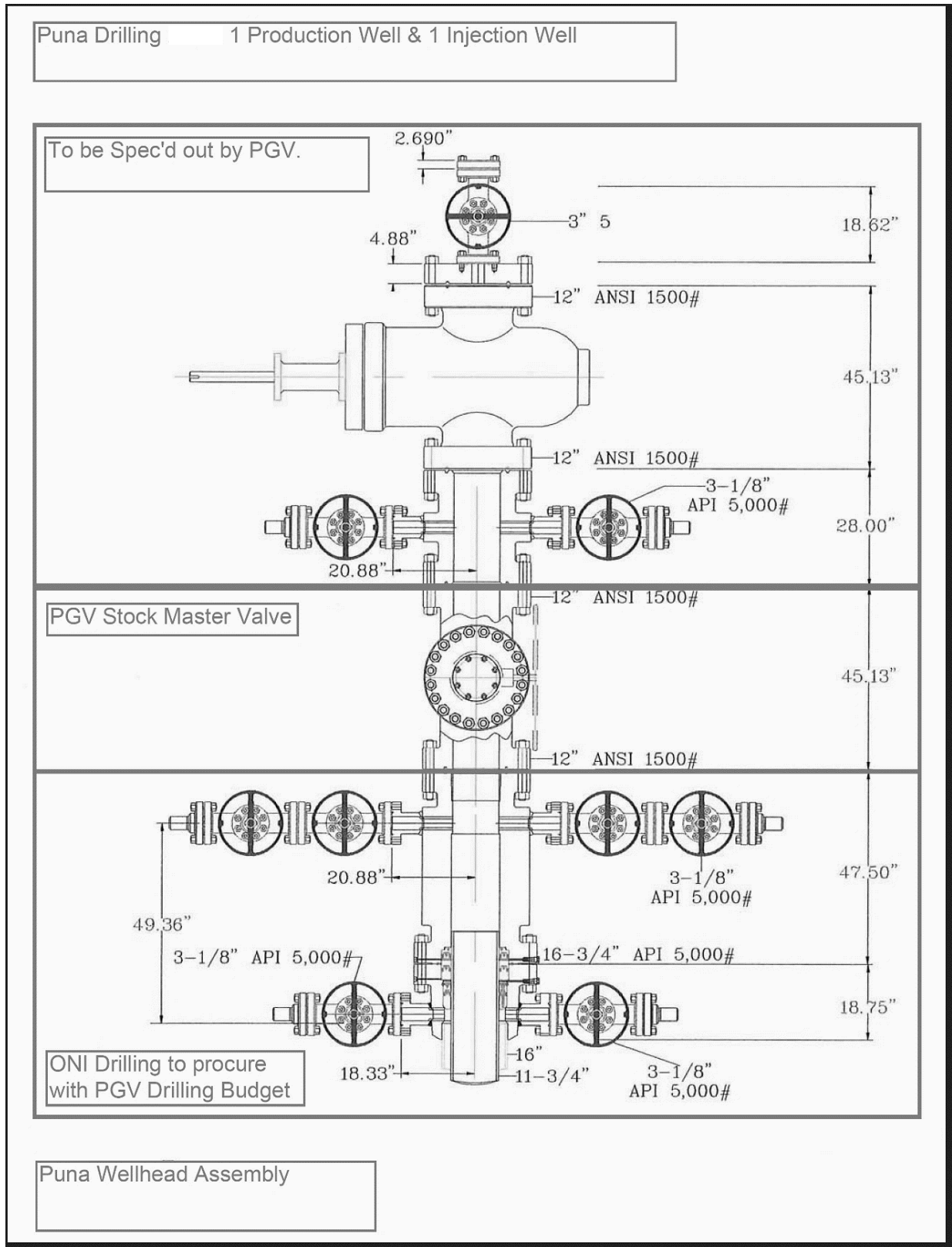

Figure 6. Proposed KS-19 wellhead assembly.

APPENDIX A

DETAILED DRILLING PROCEDURES

(All depths referenced to KB unless specified)

Location:	UTM Coordinates (NAD 83) Grid E (m) 301534 Grid N (m) 2154576
Ground Elevation:	619ft MSL
KB:	Rig#1 27 ft above ground
KB Elevation:	646 ft MSL
Objective:	Drill a new geothermal well in the Puna field, Hawaii
Status:	New Well – See Figure 2 for proposed well schematic and Figure 6 for final proposed wellhead assembly.
Regulatory Agency:	Hawaii Department of Land and Natural Resources (DLNR)

Prepare Well Pad and Set Cellar

1. Level the existing pad as needed. The area adjacent to the pad contains the containment basin. The pad must be constructed to standard industry specifications that include soil compaction suitable to support the rig's gross dead-weight plus 750,000 pounds of live loads, and capable of supporting heavy and frequent traffic. The pad must be contoured to drain into the well cellar from the area around the rig. A fence will be installed around the containment basin on the three sides away from rig.
2. Install a concrete cellar according to the rig specifications with 11 ft depth.

Set 30-inch Conductor

3. Move in (MI) and rig up (RU) a rat-hole drilling rig. Dig a 48-in. hole to 85 ft below ground. Run 60 ft of 30-in. 0.50-in. wall Grade B PEBFW line-pipe for conductor. Center conductor. Cement conductor in tension with 10 cu yd of ready-mix concrete. Two percent calcium chloride (CaCl_2) may be utilized depending on air and ground temperature. If used, CaCl_2 must be added at site to prevent solidification during transport. The next day, determine top of cement. If required, dump additional cement until it is within 5 ft of the cellar bottom.
4. Rig down (RD) and move out rat-hole drilling equipment.

Move In and Rig Up Drill Rig

5. Move in rotary drilling rig and associated drilling equipment. Rig up all equipment.
6. Post well sign, all applicable permits, and emergency telephone numbers at the rig. All drill pipe, drill collars, and cross-overs must have passed an IADC-API Class II inspection since last used.
7. Move in and RU mud-logging unit that includes a two-sensor hydrogen sulfide and CO_2 alarm system. Hydrogen sulfide and CO_2 sensors will be placed on rig floor and at the mud-return pit.



8. Install direct communications between rig floor, tool pusher, mud loggers, mud engineer, and company man. **A real-time monitoring system with monitors will be installed and personnel will be trained on the system.**
9. Hold safety meeting regarding equipment, procedures for well control, hydrogen sulfide, CO₂ general safety, and environmental protection. At meeting, discuss drilling program, geological prognosis, directional program, chain of command, emergency procedures (including telephone numbers), and other issues related to previous wells drilling performance. Drilling Supervisor and Tool Pusher must complete rig safety inspection form (Appendix I). **The rig will not be allowed to spud until both the Drilling Supervisor and Tool Pusher have signed the Safety Inspection form.**
10. Line up 1200-gpm water-supply line to the mud pits and water storage. Mix-spud mud in the pits. Drill rat and mouse hole to drilling rig specifications.
11. Weld the 30-in. flow nipple with flow line and connect to the shakers. Weld 2-in. fill-up line. Weld 3-in. valve 1 ft. above floor of cellar for drainage. Ensure that all mud-cleaning equipment is in good running condition.

Drill 26-inch Hole with Mud Motor to 1050 ft

12. Make up (MU) 26-in. drilling assembly with mud motor. Run jars in all assemblies. Run into hole (RIH) and drill 26-in. hole with gel-based mud (see Mud Program, Appendix C) to **±1050 ft**. Collect, wash, and bag three sets of rock cuttings every 10 ft. if circulation permits. Take directional surveys every 90 ft and keep well deviation within 2° total deviation and dog leg to less than 2°/100 ft over the 26-in. hole interval. Final casing point will be determined by well-site geologist. If significant lost circulation occurs, cure with lost-circulation material (LCM).
13. **Upon drilling to depth of the ground water (usually at sea level), a representative sample of the ground water will be taken and analyzed.** At **±610 ft** (sea level) rig up and pump clean water sample for DLNR. **Notify DLNR 24-hours prior to sampling.** Run a submersible pump on drill pipe, strapping electric line to drill pipe. Collect a representative water sample of ground water.
14. Continue drilling 26-in. hole with gel-based mud to **±1050 ft**. Collect, wash, and bag three sets of rock cuttings every 10 ft. if circulation permits. Take directional surveys every 90 ft and keep well deviations within 2° total deviation and dog leg to less than 2°/100 ft over the 26-in. hole interval. Final casing point will be determined by well-site geologist. If significant lost circulation occurs, cure with lost-circulation material (LCM), otherwise mud up; do not expect to fully heal lost circulation.
15. At the total depth (TD) for the 26-in. hole (that is, the 22-in. casing point), make up reaming assembly. Ream hole to TD and condition mud and hole for casing. Circulate hole clean and wipe the hole. Circulate the hole clean and POH for casing.



Set and Cement 22-inch Casing

16. RU casing crew. Drift test and visually inspect casing and threads. Run **±1050 ft** of 22-in., Grade B, 114.8-lb/ft casing PEBFW with stab-in float shoe (no float collar) (see Appendix D). Have casing measured to reach 3 to 5 ft. off bottom. Centralize casing at 5-ft. above shoe and 5-ft. above float and every third joint to 30-in. shoe. **DO NOT RUN CENTRALIZERS INSIDE 30-IN. CASING.** Have the 22-in. circulating swedge on the rig floor. Reciprocate casing while circulating and conditioning mud prior to cement job. Rig down (RD) casing crew.

17. RU cementing unit. Centralize and set the casing in the slips and trip in the hole with centralizers on the drill pipe (DP). Rabbit the drill pipe as it is picked up prior to running in the hole. Stop 2 ft. from float shoe, circulate 2 barrels (bbls) per minute for 2 minutes, shut off pump, and stab into float shoe with stab-in stinger. Circulate the hole clean and cool down the well. **ENSURE THAT CASING IS PROPERLY CENTERED BEFORE PUMPING CEMENT. SECURE CASING AS NEEDED TO PREVENT FLOATING DURING CEMENT JOB.**

Pump 30 bbls of water. Pump 20 bbls of mud. Pump 30 bbls of 10.5 ppg sepiolite spacer. Pump 5 bbls of water. Pump 13 bbls of Sodium Silicate Preflush. Pump 5 bbls of water.

Pump Lead Cement: Pump **1,000 cu ft** of 13.0 ppg Premium Cement with 30% silica flour SSA-1, 10% Micro-silica 10 lb./sk Spherelite, 3% calcium chloride, and normal chemicals mixed with fresh water (see Appendix E).

Pump Tail Cement: Pump **356 cu. ft.** of 15.0 ppg Premium Cement with 30% silica flour, SSA-1, 10% Micro-silica mixed with fresh water, 3% calcium chloride and normal chemicals.

Monitor returns throughout the job. If lead cement returns to surface, switch to tail cement. If there are no returns to surface, then pump all lead cement followed by tail cement. Pump displacement. Check if floats are holding while stabbed in. POH with stab-in tool. **The estimated static temperature at 1025 ft is 90°F.** Record start of pumping time and time of cement returns. If cement returns to surface sample and measure density. Keep water out of 22-in. x 30-in. annulus. RD cementing unit.

Note*Slurry Design is for 125°F bottom-hole static temperature (BHST); CaCl₂ or retarder may be required if BHST changes**

18. Wait on cement (WOC) until cement samples at surface have hardened or 12 hours after initial cement job. Tag top of cement in annulus after six hours with 1-1/2-in. tremie pipe. If cement has fallen, perform top job with ready-mix concrete and #9 crushed blue rock to fill annulus. Order out at least 30 yards ready-mix concrete. Add sodium silicate to annulus as needed. Add one-barrel sodium silicate to each yard of ready-mix concrete if available. Wait six hours and repeat top job if necessary.

Nipple Up 21-1/4-inch 2M BOPE and Test BOPE

19. Cut off 30-in. conductor pipe to 6-in. above cellar floor (Check with PGV/Gary Dahl to confirm cut-off depths). Cut off 22-in. casing 49-in. (Company Man to confirm) above the

ground level to allow space for proper positioning of the BOPE stack. Weld on 21-1/4-in. 2M by 22-in. casing head with two 3-1/8-in. 5M flanged side outlets on the 20-in. casing, utilizing API 5CT welding specifications for grade K-55 casing. Nipple up 21-1/4-in. 2M API diverter stack with annular preventer and flow tee (banjo box) per Figure 3. Function test diverter stack and related equipment per the standards specified in Section V of Circular C-125: “Hawaii Geothermal Blowout Prevention Manual” (HI C-125).

20. Test annular and side outlet valves to pressure specified by DLNR. Log tests on tour sheets. Report all tests on tour sheet and have mud loggers prepare pressure plots.

Formation Integrity Test in Formation Outside 22-inch Casing Shoe

21. MU 20-in. slick drilling assembly. Clean out top of 22-inch float shoe and pressure test to pressure specified by DLNR. Drill out the 22-inch float shoe after permission from DLNR.
22. Drill out of cement and at least 1’ into NEW formation (below any rathole) to perform Formation Integrity Test (FIT). Conduct FIT to a 0.65 psi/ft. gradient, if test fails, clean out hole and squeeze cement using tail-cement mixture. Wait on cement. MU 20-in. stabilized drilling assembly with mud motor and float. Clean out cement and re-run FIT until successful. Record Formation Integrity Test pressure and mud weight. Follow DLNR’s Recommended Practice for Running FIT tests, included in Appendix K.

Drill 20-inch Directional Hole with Mud Motor to 2200 ft

23. Upon successful FIT, drill 20-in. hole using directional drilling assembly. KOP is 1800’. Drill to approximately 2200 ft. Use flex subs below the drilling jars, and make sure to have shock tools, and drilling jars on all bottom-hole assemblies (BHAs). If significant lost circulation occurs, attempt to cure with *PRIMA SEAL LCM*. If LCM does not work, drill until a cement plug is required; for cement use the 22-in. tail mixture. POH.

Obtain bottom-hole temperature from directional tools and compare to mud-logging surface temperature prior to mixing cement.

24. Turn mud cooler on before flow-line temperature exceeds 110°F. Be prepared to set casing if there are any signs of encountering a high-temperature reservoir. Catch 10 ft. samples of drill cuttings and monitor for changes in mineralogy indicative of high-temperature geothermal reservoir. Continuously monitor well for flow and gases.
25. Run all solids-control equipment as needed. Use coarse shale-shaker screens if necessary, to handle 750 – 850 gpm circulation rates.
26. Function Test BOPE every time a trip is made. Record test on tour sheets.
27. Condition hole for casing.
28. Wash and ream hole to bottom. Monitor well and make sure well takes proper amount of fluid. Casing point is to be decided by well-site geologist.

Set and Cement 16-inch Casing

29. RU casing crew. Drift test casing and visually inspect threads. Run ± 2200 ft of 16-in., 84-lb./ft., L-80 GB Buttress casing with swell packer, stab-in float collar and float shoe. Swell packer must be located inside the 22-in. casing. Centralize casing at 5 ft above shoe and 5 ft above float and every third joint. Tack-weld bottom three joints. Do not exceed running speed of one joint per 30 seconds to prevent surge. Fill casing with mud while running to overcome buoyancy. Center the casing in the rotary table. Rig down (RD) casing crew.

Obtain bottom-hole temperature from directional tools and compare to mud-logging surface temperature prior to mixing cement.

30. **Prepare to pump foamed cement job. Refer to Cementing Program (Appendix E).** RU-cementing unit. RIH with 5-in. drill pipe with stab-in stringer and pump 2 bbls to clear the stab-in string prior to stabbing in. Stab into float collar and circulate until the well is cool enough to cement. Pump 20 bbls of water. Pump 60 bbls of foamed water. Pump 13 bbls of foamed Sodium Silicate. Pump 5 bbls of foamed water.

Pump Scavenger/Excess Cement: Pump **1624 cu ft** of 10-ppg foamed cement with 30% silica flour SSA-1, 10% Micro-silica mixed with fresh water and normal chemicals.

Pump Foamed Lead Cement: Pump **1412cu ft** of 11-ppg foamed premium cement with 30% silica flour SSA-1, 10% Micro-silica mixed with fresh water, 1.5 gal Latex per sk, and normal chemicals.

Pump Non-Foamed Lead Latex Cement: Pump **412 cu ft** of 13.5-ppg premium cement with 30% silica flour SSA-1, 10% Micro-silica mixed with fresh water, 1.5 gal Latex per sk, and normal chemicals.

Pump Non-Foamed Tail Latex Cement: Pump **455 cu ft** of 15-ppg premium cement with 30% silica flour SSA-1, 10% Micro-silica mixed with fresh water, and normal chemicals. Pump Displacement. Pump Cap Cement Down Annulus: Pump 245 cu ft of 15-ppg cement down annulus. The estimated static temperature at 2525 ft is 300°F; however, circulating temperature will be much lower.

Monitor returns throughout the job. Record time start of pumping and of cement returns. RD cementing unit. Keep water away from annulus.

31. Displace cement with mud. Check if float is holding while stabbed in. Pull out of hole with stab-in tool. Keep water away from 16-in. x 22-in. annulus.
32. Wait on cement (WOC) until cement samples have hardened or for at least 8 hours. Tag top of cement in annulus with 1-1/2-in. tremie pipe after six hours. Perform top job utilizing premium cement with 30% silica flour SSA-1, 10% Micro-silica mixed with fresh water, and normal chemicals, if necessary. Wait six hours and repeat top job if necessary. (Note: At the discretion of the drilling engineer and supervisor, the top job, if required, may be done by means of a top squeeze.)

Install 16-inch Casing Head, Nipple Up 16-3/4-inch 5M BOPE & Test BOPE

33. Lift 21-1/4-in. 2M BOP and make an initial cut on 16-in. casing. Lay down cut off casing and nipple down BOP. Cut off the 22-in. casing 6-in. above the 30-in. casing (confirm with PGV/Gary Dahl all cut-off heights). Cut off 16-in. casing. Using a qualified welder and proper pre-, post-weld heat treatment and stress relief, weld on 16-3/4-in. 5M by 16-in. SOW casing head with two 3-1/8-in. 5M flanged side outlets utilizing SMAW Welding of API 5CT Type L-80 Steels welding specifications. Test casing head to 1000 psi with nitrogen. Nipple up BOPE per Figure 4. Pressure test BOPE and casing to pressures specified by DLNR. Function test BOPE per the standards specified in Section V of HI C-125. Report all tests on tour sheet and have mud loggers prepare pressure plots.
34. MU 14-3/4-in. directional drilling assembly with float, in preparation to drill out the casing shoe and eliminate trips RIH to the top of cement. Pressure test pipe rams to pressure specified by Department of Land and Natural Resources. Log the test result on the tower sheet and morning report. Clean out to the top of the float collar and pressure test the casing to pressure specified by DLNR. Drill out the float collar and half-way down the shoe track, and pressure test casing to pressure specified by DLNR.

Formation Integrity Test in Formation Outside 16-inch Casing Shoe

35. Drill out of cement and at least 1' into NEW formation (below any rathole) to perform Formation Integrity Test (FIT). If test fails, clean out hole and squeeze cement using tail cement mixture. Wait on cement. MU 14-3/4-in. directional drilling assembly with float. Clean out cement and at least 1' into NEW formation (below any rathole) re-run FIT until successful. Record (1) Formation Integrity Test pressure and mud weight; (2) BOPE Pressure out. Follow DLNR's Recommended Practice for Running FIT tests, included in Appendix K.

Drill 14-3/4-inch Hole with Directional Tools to 3200 ft

36. Upon successful FIT, drill 14-3/4-in. hole using directional drilling assembly. RIH and drill to **±3200 ft**. Take directional surveys every 90 ft. Keep well within 50 ft of directional drilling program. Use drilling jars, and make sure shock tools and drilling jars are on all BHA's. Catch 10 ft. grab samples of drill cuttings. Monitor well for flow changes and for any gas flows. Keep close watch on samples for changes in mineralogy indicative of high-temperature geothermal reservoir. Run liner earlier if there are any signs of high-temperature reservoir. Rotate through all slide sections prior to making connections. POH.
37. Function test BOPE on every trip. In case of total losses or after the direction and angle has been established, pull out of hole with directional BHA and continue drilling ahead to TD with conventional rotary locked BHA. Record BOPE test on tour sheets.
38. Circulate and condition hole for casing. POH. **Obtain bottom-hole temperature from directional tools and compare to mud-logging surface temperature prior to mixing cement.** (For example, the last readings from MWD tool in KS-16, March 31, 2015, were between 138°F and 141°F).



Set and Cement 11-7/8-inch Casing

39. Prepare to run 11-7/8-in. casing. RU casing crew. Drift test casing and visually inspect threads. Run ± 3200 ft of 11-7/8-in., 71.8-lb./ft., C-110 BG CD Butt casing with float collar and float shoe.
40. RU BOP lift equipment and verify operational while rigging up to run 11-7/8" casing as follows:
 - Float shoe
 - 1 joint 11-7/8" casing with centralizer on stop ring half-way up
 - Stab-in float collar
 - 1 joint 11-7/8" casing with centralizer on stop ring half-way up
 - Remainder 11-7/8" casing with a centralizer on every third coupling **except no couplings on top 300'**
 - **Casing to be set at +/-3200' MD**

NOTE: Use Green-Seal II Thermal thread compound on casing connections

Do not run casing faster than 45 seconds/joint to minimize surge

Fill casing every 5 joints while RIH

41. Fill well and monitor 30minutes to make sure it's stable prior to removing BOPs. Make sure we are rigged up to circulate cold water at all times.
42. ND BOP at wellhead and mud cross, ND diverter, choke, kill and flow lines. Raise and secure BOPs with hydraulic lift and braces. Install centering ring around casing per TNG and tack weld same.
43. Lower BOPs and re-bolt. There is no way to test break prior to cement setting up
44. RU false rotary & run 5" DP for inner string cement job. Stab into float collar.
45. **Prepare to pump foamed cement job.** Refer to Cementing Program, Appendix E. Rig up cementing unit. Pump 20 bbls of water. Pump 60 bbls of foamed water. Pump 13 bbls of foamed Sodium Silicate. Pump 5 bbls of foamed water.

Pump Scavenger/Excess Cement: Pump **1070 cu ft** of 10-lb/gal foamed Premium Cement with 30% silica flour, 10% micro-silica, retarder, free-water polymer, and normal chemicals.

Pump Foamed Lead Cement: Pump **1566 cu ft** of 11-lb/gal foamed Premium Cement with 30% silica flour, 10% micro-silica, retarder, free-water polymer, and normal chemicals.

Pump Non-Foamed Tail Cement: Pump **525 cu ft** of 15-lb/gal Premium Cement with



30% silica flour, 10% micro-silica and normal chemicals. Report time of cement returns. Displace cement.

Pump Cap Cement Down Annulus: Pump **106.8 cu ft** of 15-ppg cement down annulus. POH. Keep water away from annulus. Wait on cement for 12 hours. Estimated static temperature at 4700 ft is 575 °F.

46. Wait on cement (WOC) until cement samples have hardened or for at least 8 hours. Tag top of cement in annulus with 1-1/2-in. tremie pipe after six hours. If necessary, perform top cement job utilizing premium cement with 30% silica flour SSA-1, 10% micro-silica mixed with fresh water and necessary chemicals. Wait six hours and repeat top job, if necessary. (Note: At the discretion of the drilling engineer and supervisor, the top job, if required, may be done by means of a top squeeze.)

Install 16-inch Expansion Spool, Re-Install and Test 16-3/4-inch 5M BOPE

47. Install 16-inch x 12-inch expansion spool and 12-inch master valve. Re-install BOPE according to Figure 5.
48. MU 10-1/2-in. directional drilling assembly with float, in preparation to drill out the casing shoe and eliminate trips. RIH to the top of cement. Pressure test pipe rams, blind rams, and preventer to pressure specified by DLNR. Function test BOPE per the standards specified in Section V of HI C-125. Log the test results on the tower sheet and morning report. Clean out to the top of the float collar and pressure test the casing to pressure specified by DLNR. Drill out the float collar and half-way down the shoe track, and pressure test casing to pressure specified by DLNR. Report all tests on tour sheet and have mud loggers prepare pressure plots.

Formation Integrity Test in Formation Outside 11-7/8-inch Casing Shoe

49. Drill out of cement and at least 1' into NEW formation (below any rathole) to perform Formation Integrity Test (FIT). Conduct FIT to a 0.65 psi/ft. gradient. If test fails, clean out hole and squeeze cement using tail cement mixture. Wait on cement. MU 10-1/2-in. directional drilling assembly with float. Clean out cement and at least 1' into NEW formation (below any rathole) re-run FIT until successful. Record: (1) Formation Integrity Test pressure and mud weight; (2) BOPE Pressure out. Follow DLNR's Recommended Practice for Running FIT tests, included in Appendix K.

Drill 10-1/2-inch Hole with Directional Tools to 4686 ft

50. Upon successful FIT, drill 10-1/2-in. hole with directional drilling assembly and float. RIH and directionally drill a 10-1/2-in. hole to **±4686 ft**. TD will be decided by well-site geologist. Keep hole within 50 ft of directional program. POH. Stand back bit and bottom hole assembly.
- 51.



Water-Loss Test (for permeability)

52. Prepare for Water-Loss Test (Step-Rate Geothermal Test). Obtain test plan from PGV's Drilling Engineer or Reservoir Engineer. Rig up wire-line unit for running Pressure-Temperature tool. Run open-ended drill pipe to depth per test plan. POH and stand back drill pipe. Keep water running into hole.

Run and Hang 8-5/8-inch Slotted Liner

53. Circulate hole and prepare mud for liner. RU casing crew. Drift-test liner and visually inspect threads. Run ± 1480 ft of 8-5/8-in., 59.6-lb./ft., TN-110SS Hydril 563 with liner hanger and guide shoe. Keep water running into hole. Make up the liner-hanger adapter and run liner in the hole on drill pipe. Hang liner +/-10ft off bottom with liner hanger +/-100' above 11-7/8" shoe. Release the liner hanger and pull out of hole. . POH and lay down drill pipe. Keep water running into hole.

Run & Hang 9-5/8-inch Hang-down Liner

54. If the well is designated a reinjection well, a hang down liner will be installed. If it is a production well skip this step. Circulate hole and prepare to run hang-down liner. Drift-test liner and visually inspect threads. Run ± 3000 ft of 9-5/8-in., 53.5-lb/ft, T95 FMAX III Flush Joint hang-down liner. Install hanger in casing head with donut hanger and hang from surface. Pump nitrogen on the backside. Keep water running into the hole.
55. Close master valve. Nipple down BOPE.

Rig Down

56. RD mud logging unit. RD and release drilling equipment. Lock wellhead valve.



APPENDIX B DIRECTIONAL DRILLING PLAN

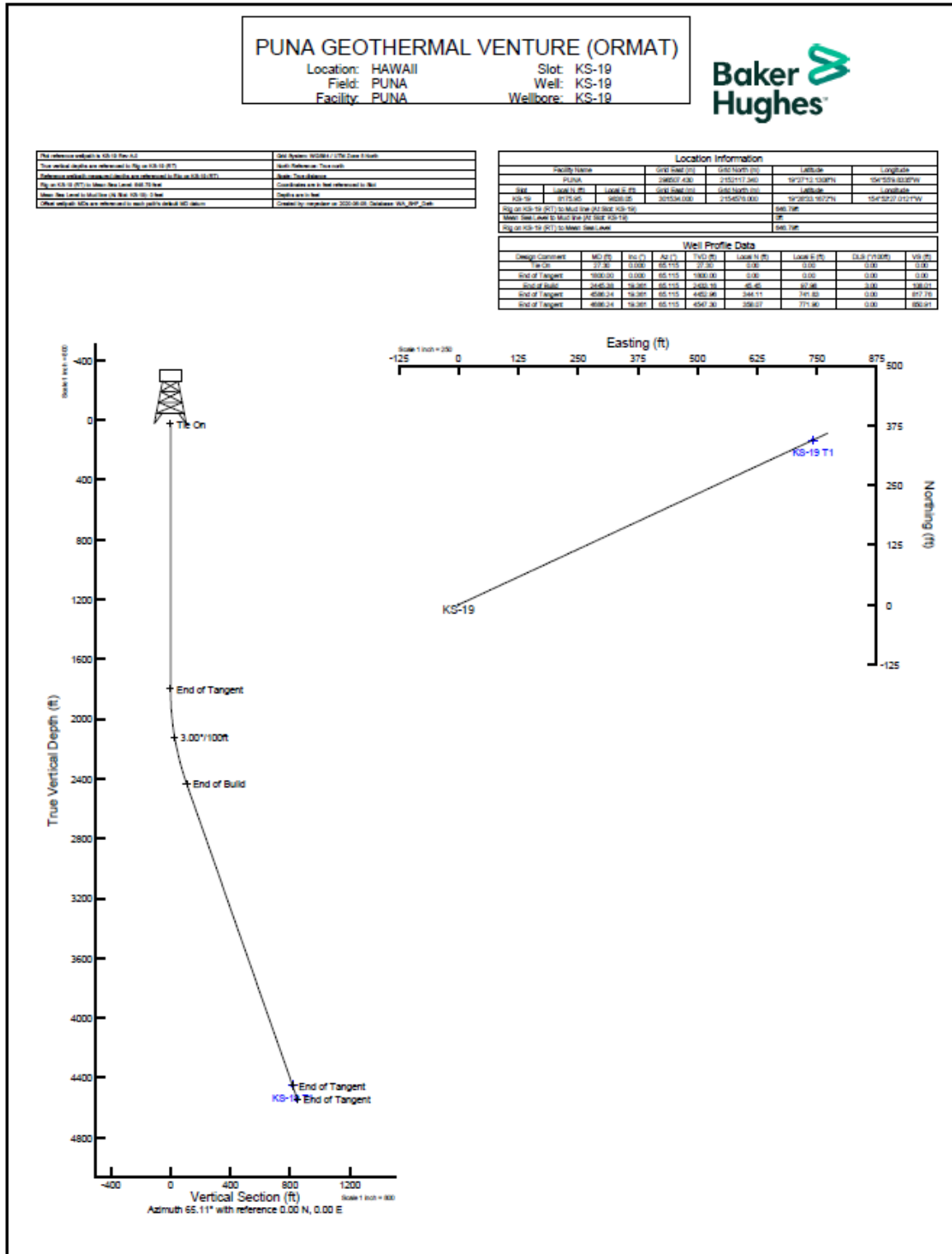



APPENDIX C MUD PROGRAM

A. MUD PROGRAM GENERAL GUIDELINES:

Use low-solids, non-dispersed mud with additives as necessary for system control. The following parameters should be maintained:

0-±4686 ft

Mud Weight:	≤9.2 pounds per gallon (ppg) unless it is necessary to weight up to control artesian flow.
Funnel Viscosity:	35 to 45 sec/qt
API FL:	8 to 10 ml/30 min
PV:	9 to 12 cps
YP:	7 to 15 lbs/100 ft ²
Initial Gel:	3 to 6 sec
pH:	10 to 10.5

Mud-Cleaning Equipment: Mud Cleaner. Continuously use mud-cleaning equipment to remove solids.

Maintain sufficient barite on location to control well at all times. Monitor well for flow, CO₂, and H₂S at all times and increase mud weight to control. Maintain H₂S-control chemicals on site.

B. DETAILED MUD PROGRAM PER GEO DRILLING FLUIDS, INC:

105 ft-1050 ft Drilling 26-inch hole for 22-inch casing: No circulation is expected while drilling this section. Maintain a 35 – 45 vis in the suction pit at all times with gel and Benex. In the pill pit, have a 60 – 70 vis pill with 10 ppb LCM ready to be used as needed. Mix fresh gel and water (in the suction pit) to a 35 - 45 sec/qt funnel viscosity w/ minimal additions of Drispac R. Sweep hole as often as necessary with 60 – 70 vis pill with 10 ppb Fiberseal.

At total depth, pump 2-70 bbl high viscosity sweeps prior to pulling out of the hole to run casing. Sweep to consist of base mud, 10 ppb Fiberseal and 0.1 to 0.2 ppb Lime.

1050 ft-2200 ft Drilling 20-inch hole for 16-inch casing: Pre-treat for cement drill-out and residual Lime with 6 sacks Bicarbonate of Soda.

Drill out casing and reduce filtrate loss to 7-8 cc’s with 1 ppb Drispac R. Add fresh Gel and Zanflow/Flowzan to increase funnel viscosity to ~50-55 sec/qt with a minimum yield point of 20 lbs/100 ft².



In the pill pit have a 60 – 70 vis pill with gel, Zanflow/Flowzan, and 10 ppb Fiberseal ready to pump as needed for lost circulation or hole cleaning.

Compound mud pumps to achieve maximum annular velocities.

Mud Weight: Maintain mud weight at ≤ 9.2 ppg. Run centrifuge on a 24-hour basis. Run the mud cleaner at all times while circulating mud. The mud cleaner should be equipped with ≥ 250 -mesh screens. If the mud weight exceeds 9.4 ppg then a dump and dilute program should be instituted.

Viscosity: Maintain a minimum yield point of 20-25 lbs/100 ft² with fresh Gel, Zanflow/ Flowzan and LP-701 as needed. It is estimated that this will require a funnel viscosity ≥ 50 sec/qt. In the pill pit increase viscosity to 75-100 sec/qt and add 10 ppb Fiberseal and sweep hole every 500 ft drilled. Time and monitor sweeps for dilution and excess cuttings. Include in the analysis any additional solids discharge from mud cleaner. Viscosity should be a minimum of 35 sec/qt greater than the base fluid. If the sweep comes back diluted ≥ 20 sec/qt, then the volume and viscosity should be increased. If sweeps continue to produce unacceptable volumes of cuttings, then increase yield point. In the event of bit balling, sweep hole with walnut hulls and DMS.

Filtrate Loss: Maintain filtrate loss at 7 – 8 cc’s with hourly treatments of Drispac R. Treatments should be designed to maintain a ~ 1.25 ppb concentration. The filter-cake should be scrutinized daily. A thin, pliable, slick filter-cake is desired. Occasional fresh bentonite treatments may be necessary to provide the proper base material if the previously described properties are not achieved.

pH: Maintain a 10 – 10.5 pH with lime and soda ash for H₂S abatement. Amber HS may also be utilized.

Solids: Maintain solids at 8% or as low as practical. Shakers should be fitted with screens that allow mud travel 2/3 of the screen length. Mud cleaner should be fitted with at least 250-mesh screens. The centrifuge should be run on a 24 hour basis. If necessary, dump and dilute. Discuss dump-and-dilute program with drill-site manager before taking action.

<u>Mud Weight</u>	<u>Viscosity</u>	<u>Filtrate</u>	<u>pH</u>	<u>Solids</u>
9.0-9.2 ppg	≥ 50 sec/qt	7-8 cc’s	10-10.5	4-8%

2200 ft – 3200 ft Drilling 14 3/4inch hole for 11 7/8 inch casing: Pre-treat for cement drillout with 6 sacks Bicarbonate of Soda. Continue to compound mud pumps at maximum outputs.

Mud Weight: Maintain mud weight at ≤ 9.2 ppg. Run centrifuge on a 24-hour basis. Run the mud cleaner at all times while circulating mud. The mud cleaner should be equipped with ≥ 250 -mesh screens. If the mud weight exceeds 9.4 ppg then a dump and dilute program should be instituted.

Viscosity: Maintain a minimum yield point of 15-18 lbs/100 ft² with fresh Gel, Zanflow/ Flowzan and LP-701 as needed. It is estimated that this will require a funnel viscosity ≥ 45 -sec/qt. In the pill pit, increase viscosity to 75-100 sec/qt and add 10 ppb Fiberseal, and sweep hole every 500 ft

drilled. Time and monitor sweeps for dilution and excess cuttings. Include in the analysis any additional solids discharge from mud cleaner. Viscosity should be a minimum of 35 sec/qt greater than the base fluid. If the sweep comes back diluted ≥ 20 sec/qt, then the volume and viscosity should be increased. If sweeps continue to produce unacceptable volumes of cuttings, then increase yield point. In the event of bit balling sweep hole with walnut hulls and DMS.

Filtrate Loss: Maintain filtrate loss at 7-8 cc's with tourly treatments of Drispac R. Treatments should be designed to maintain a ~1.25 ppb concentration. The filter-cake should be scrutinized daily. A thin, pliable, slick filter-cake is desired. Occasional fresh bentonite treatments may be necessary to provide the proper base material if the previously described properties are not achieved.

pH: Maintain a 10 – 10.5 pH with lime and soda ash for H₂S abatement. Amber HS may also be utilized.

Solids: Maintain solids at 8% or less. Shakers should be fitted with screens that allow mud travel 2/3 of the screen length. Mud cleaner should be fitted with 325-mesh screens, if possible. The centrifuge should be run on a 24-hour basis. If necessary, dump and dilute. Discuss dump-and-dilute program with drill site manager before taking action.

<u>Mud Weight</u>	<u>Viscosity</u>	<u>Filtrate</u>	<u>pH</u>	<u>Solids</u>
9.0-9.2 ppg	≥ 45 sec/qt	7-8 cc's	10-10.5	4-8%

3200 ft – 4686 ft Drilling 10-1/2-inch hole for 8 5/8-inch liner: Pre-treat for cement drill-out with 2 sacks Bicarbonate of Soda. Continue to compound mud pumps at maximum outputs.

In this geothermal section, reduce the gel content to a maximum of 5 ppb bentonite and maintain a 35-38 vis in the suction pit with 5 ppb gel, 0.5 ppb Drispac R, and 1.0 ppb Zanflow/Flowzan. Also in this section, maintain 3-4 ppb Fiberseal (micronized cellulose) in the suction pit to minimize lost circulation. In the event of total lost circulation, drilling blind with water and utilizing sweeps as often as directed by Company Man may be implemented.

Mud Weight: Maintain mud weight at ≤ 9.2 ppg. Run centrifuge on a 24-hour basis. Run the mud cleaner at all times while circulating mud. The mud cleaner should be equipped with ≥ 350 -mesh screens. If the mud weight exceeds 9.4 ppg then a dump-and-dilute program should be instituted.

Viscosity: Maintain a minimum yield point of 10 -12 lbs/100 ft² with fresh Gel, Zanflow/ Flowzan as needed. It is estimated that this will require a funnel viscosity ≥ 35 sec/qt. In the pill pit, increase vis to 75-100 sec/qt and sweep hole with 10 ppb Fiberseal every 500 ft drilled. Time and monitor sweeps for dilution and excess cuttings. Include in the analysis any additional solids discharge from mud cleaners. Viscosity should be a minimum of 35 sec/qt greater than the base fluid. If the sweep comes back diluted ≥ 20 sec/qt, then the volume and viscosity should be increased. If sweeps continue to produce unacceptable volumes of cuttings, then increase yield point. In the event of bit balling, sweep hole with walnut hulls and DMS.



Filtrate Loss: Maintain filtrate loss at 7-8 cc's with hourly treatments of Drispac R. Treatments should be designed to maintain a ~1.25 ppb concentration. The filter-cake should be scrutinized daily. A thin, pliable, slick filter-cake is desired. Occasional fresh bentonite treatments may be necessary to provide the proper base material if the previously described properties are not achieved.

pH: Maintain a 10 – 10.5 pH with lime and soda ash for H₂S abatement. Amber HS may also be utilized.

Solids: Maintain solids at 6% or less. Shakers should be fitted with screens that allow mud travel 2/3 of the screen length. Mud cleaner should be fitted with 325-mesh screens if possible. The centrifuge should be run on a 24 hour basis. If necessary, dump and dilute. Discuss dump-and-dilute program with drill site manager before taking action.

<u>Mud Weight</u>	<u>Viscosity</u>	<u>Filtrate</u>	<u>pH</u>	<u>Solids</u>
9.0-9.2 ppg	35-38 sec/qt	7-8 cc's	10-10.5	4-6%



APPENDIX D

CASING SAFETY FACTORS

A. CASING: 22-in., 114.8-lb/ft, Grade B, PEBFW with shoe @ 1050 FT

1 BURST AT 22-in. SHOE DURING CEMENTING

- Assumes 16 lb/gal cement slurry inside and water outside.
- Inside pressure = $16 \text{ ppg} * .052 \text{ psi/ft} * 1050 \text{ ft} = 874 \text{ psig}$
- Outside pressure = $8.33 \text{ ppg} * .052 \text{ psi/ft} * 1050 \text{ ft} = 455 \text{ psig}$
- Calculated burst pressure = 419 psig
- Burst rating at specified minimum yield = 1390 psig
- Safety Factor = **332%**

2 BURST AT 22-in. SHOE DURING CASING TEST

- Assumes 8.6 lb/gal mud inside, water outside, and 500 psig test pressure.
- Inside pressure = $(8.6 \text{ ppg} * .052 \text{ psi/ft} * 1050 \text{ ft}) + 500 \text{ psig} = 970 \text{ psig}$
- Outside pressure = $8.33 \text{ ppg} * .052 \text{ psi/ft} * 1050 \text{ ft} = 455 \text{ psig}$
- Calculated burst pressure = 515 psi g
- Burst rating at specified minimum yield = 1390 psig
- Safety Factor = **270%**

3 COLLAPSE AT 22-in. SHOE DURING CEMENTING

- Assumes 8.33 lb/gal water inside and 16 lb/gal cement outside.
- Inside pressure = $8.33 \text{ ppg} * .052 \text{ psi/ft} * 1050 \text{ ft} = 455 \text{ psig}$
- Outside pressure = $(16 \text{ ppg} * .052 \text{ psi/ft} * 1050 \text{ ft}) = 874 \text{ psig}$
- Calculated collapse pressure = 419 psi g
- Collapse rating = 580 psig
- Safety Factor = **138%**

4 22-in. CASING TENSILE YIELD AS RUN

- Assumes 1050 ft of casing hung in air.
- Calculated tensile yield = $1050 \text{ ft} * 114.8 \text{ lb/ft} = 120,540 \text{ lb}$
- Tensile rating at specified minimum yield = 1,118,000 lb
- Safety Factor = **927%**

B. CASING: 16-in., 84-lb/ft, L-80, GB Buttress with shoe @ 2200 FT MD

1 BURST AT 16-in. SHOE DURING CEMENTING

- Assumes 16 lb/gal cement slurry inside & water outside with 500 psig pumping pressure.
- Inside pressure = $(16 \text{ ppg} * .052 \text{ psi/ft} * 2200 \text{ ft}) + 500 = 2330 \text{ psig}$
- Outside pressure = $8.33 \text{ ppg} * .052 \text{ psi/ft} * 2200 \text{ ft} = 953 \text{ psig}$
- Calculated burst pressure = 1377 psig
- Burst rating at specified minimum yield = 4330 psig
- Safety Factor = **314%**



2 COLLAPSE AT 16-in. SHOE DURING CEMENTING

- Assumes 8.33 lb/gal water inside and 16 lb/gal cement outside.
- Inside pressure = $8.33 \text{ ppg} * .052 \text{ psi/ft} * 2200 \text{ ft} = 953 \text{ psig}$
- Outside pressure = $16 \text{ ppg} * .052 \text{ psi/ft} * 2200 \text{ ft} = 1830 \text{ psig}$
- Calculated collapse pressure = 877 psig
- Collapse rating = 2000 psig
- Safety Factor = **228%**

3 16-in. CASING TENSILE YIELD AS RUN

- Assumes 2200 ft of casing hung in air.
- Calculated tensile yield = $2200 \text{ ft} * 84 \text{ lb/ft} = 184,800 \text{ lb}$
- Tensile rating at specified minimum yield = 1,929,000 lb
- Safety Factor = **1044%**

C. CASING: 11-7/8-in, 71.8lb/ft, C-110 BG CD Butt with shoe @3200'

1 BURST AT 11-7/8-in. SHOE DURING CEMENTING

- Assumes 16 lb/gal cement slurry inside & water outside with 800 psig pumping pressure.
- Inside pressure = $(16 \text{ ppg} * .052 \text{ psi/ft} * 3200 \text{ ft}) + 800 = 3462 \text{ psig}$
- Outside pressure = $8.33 \text{ ppg} * .052 \text{ psi/ft} * 3200 \text{ ft} = 1386 \text{ psig}$
- Calculated burst pressure = 2076 psig
- Burst rating at specified minimum yield = 9430 psig
- Safety Factor = **454%**

2 COLLAPSE AT 11-7/8-in. SHOE DURING CEMENTING

- Assumes 8.33-lb/gal water inside and 16-lb/gal cement outside and 9.0-ppg mud above hanger with cement 100 ft above hanger.
- Inside pressure = $(8.33 \text{ ppg} * .052 \text{ psi/ft} * 3200 \text{ ft}) = 1386 \text{ psig}$
- Outside pressure = $(16 \text{ ppg} * .052 \text{ psi/ft} * 3200 \text{ ft}) = 2662 \text{ psig}$
- Calculated collapse pressure = 1276 psig
- Collapse rating = 5290 psig
- Safety Factor = **415%**

3 11-7/8-in. CASING TENSILE YIELD AS RUN

- Assumes 3200 ft of casing hung in air.
- Calculated tensile yield = $3200 * 71.8 \text{ lb/ft} = 229,760 \text{ lb}$
- Tensile rating at specified minimum yield = 2,271,000 lb
- Safety Factor = **988%**

4 8-5/8-in. LINER TENSILE YIELD AS RUN

- ±1500 ft of 8-5/8-in. 59.6 lb./ft. TN-110SS Hydril 563
- Assumes 1500 ft of casing hung in air.
- Calculated tensile yield = $1500 * 59.6 \text{ lb/ft} = 89,400 \text{ lb}$
- Tensile rating at specified minimum yield = 1,917,000 lb
- Safety Factor = **2144%**



APPENDIX E CEMENTING PROGRAM

Refer to Cementing Program by Resource Cementing for Details

CASING – 22-IN., 114.8-LB/FT, GRADE B PEBFW

DEPTH – 0-1050 ft.

HOLE SIZE – 26-in.

EXISTING CASING – 30-in. Conductor 0-60 ft.

CALCULATED VOLUME – 1281.99 ft³

PROPOSED CEMENT VOLUME – 1356 ft³ (8% Excess on Open-Hole Volume)

ESTIMATED BHST: 90°F

CEMENT PARAMETERS

LEAD CEMENT (1000 cu ft.)

Premium Cement	Slurry Weight – 13.0 lb./gal
30% SSA-1	Slurry Yield – 2.50 ft ³ /sk
10% Micro-silica	Water Requirement – 11.20 gal/sk
Mixed with freshwater	Total Mixing Water – 106.67 bbls
10% Spherelite	Slurry Volume – 178.10 bbls
Normal chemicals	Cement Required – 400 sks

TAIL CEMENT (356 cu ft.)

Premium Cement	Slurry Weight – 15.0 lb./gal
30% SSA-1	Slurry Yield – 1.78 ft ³ /sk
10% Micro-silica	Water Requirement – 7.78 gal/sk
Mixed with fresh water	Total Mixing Water – 37.05 bbls
Normal chemicals	Slurry Volume – 63.4 bbls
	Cement Required – 200 sks

**CASING – 16-IN. 84# L-80 GB BUTTRESS****DEPTH** – 0-2200 ft.**HOLE SIZE** – 20-in.**EXISTING CASING** – 22-in. 0-1050 ft.**CALCULATED HOLE VOLUME** – 2247.45 ft³**PROPOSED CEMENT VOLUME** – **4445.75 ft³** (100% Excess + Shoe Track)**ESTIMATED BHST:** 300°F: monitor & confirm prior to pumping**FOAMED SCAVENGER/EXCESS CEMENT (2198.30 cu ft. Foamed Volume)**

Premium Cement	Slurry Weight – 10 lb./gal (Foamed)
30% SSA-1	Slurry Yield – 2.14 ft ³ /sk
10% Micro-silica	Water Requirement – 8.91 gal/sk
Mixed with freshwater	Total Mixing Water – 161.23 bbls
Foam	Slurry Volume – 289.66 bbls (Base Slurry)
Normal chemicals	Slurry Volume – 391.04 bbls (Foamed)
	Cement Required – 760 sks

FOAMED LEAD CEMENT (1156cu ft. Foamed Volume)

Premium Cement	Slurry Weight – 11 lb./gal (Foamed)
30% SSA-1	Slurry Yield – 2.14 ft ³ /sk
10% Micro-silica	Water Requirement – 8.91 gal/sk
Mixed with freshwater	Total Mixing Water – 114.56 bbls
Foam	Slurry Volume – 205.81 bbls (Base Slurry)
Normal chemicals	Slurry Volume – 252.89 bbls (Foamed)
	Cement Required – 540 sks

NON-FOAMED LEAD LATEX CEMENT (412.3 cu ft.)

Premium Cement	Slurry Weight – 13.5 lb./gal
30% SSA-1	Slurry Yield – 2.17 ft ³ /sk
10% Micro-silica	Water Requirement – 9.12 gal/sk
Mixed with freshwater	Total Mixing Water – 41.26 bbls
Foam	Slurry Volume – 73.43 bbls
Normal chemicals	Cement Required – 190 sks

NON-FOAMED TAIL LATEX CEMENT (455 cu ft.)

Premium Cement	Slurry Weight – 15.0 lb./gal
30% SSA-1	Slurry Yield – 1.75 ft ³ /sk
10% Micro-silica	Water Requirement – 7.78 gal/sk
Mixed with freshwater	Total Mixing Water – 48.16 bbls
Normal chemicals	Slurry Volume – 81.04 bbls
0.175% SCR-100	Cement Required – 260 sks

CAP CEMENT PUMPED DOWN ANNULUS (245 cu ft. of 15.0-lb/gal cement)



CASING – 11-7/8-IN. 71.8-LB/FT C-110 BG CD Butt

DEPTH – 0-3200 ft.

HOLE SIZE – 14-3/4-in.

EXISTING CASING – 16-in. 0-2200 ft.

CALCULATED HOLE VOLUME – 2168 ft³

PROPOSED CEMENT VOLUME – **2879 ft³** (33% Excess on Open-Hole Volume)

ESTIMATED BHST: 300°f: monitor & confirm prior to pumping

FOAMED SCAVENGER/EXCESS CEMENT (1447.42 cu ft. Foamed Volume)

Premium Cement	Slurry Weight – 10 lb/gal (Foamed)
30% SSA-1	Slurry Yield – 2.14 ft ³ /sk
10% Micro-silica	Water Requirement – 8.91 gal/sk
Mixed with freshwater	Total Mixing Water – 106.07 bbls
Foam	Slurry Volume – 190.57 bbls (Base)
Normal chemicals	Slurry Volume – 257.27 bbls (Foamed)
	Cement Required – 500 sks

FOAMED LEAD CEMENT (1284 cu ft. Foamed Volume)

Premium Cement	Slurry Weight – 11 lb/gal (Foamed)
30% SSA-1	Slurry Yield – 2.14 ft ³ /sk
10% Micro-silica	Water Requirement – 8.91 gal/sk
Mixed with freshwater	Total Mixing Water – 127.29 bbls
Foam	Slurry Volume – 228.68 bbls (Base)
Normal chemicals	Slurry Volume – 280.65 bbls (Foamed)
	Cement Required – 600 sks

NON-FOAMED TAIL CEMENT (525 cu ft.)

Premium Cement	Slurry Weight – 15.0 lb/gal
30% SSA-1	Slurry Yield – 1.75 ft ³ /sk
10% Micro-silica	Water Requirement – 7.78 gal/sk
Mixed with freshwater	Total Mixing Water – 55.57 bbls
Normal chemicals	Slurry Volume – 93.5 bbls
0.175% SCR-100	Cement Required – 300 sks

CAP CEMENT PUMPED DOWN ANNULUS (106.80 cu ft. of 15.0-lb/gal cement)

Premium Cement	Slurry Weight – 15 lb/gal (Foamed)
30% SSA-1	Slurry Yield – 1.78 ft ³ /sk
10% Micro-silica	Water Requirement – 7.78 gal/sk
Mixed with freshwater	Total Mixing Water – 11.11 bbls
Foam	Slurry Volume – 19.02 bbls
Normal chemicals	Cement Required – 60 sks



APPENDIX F EMERGENCY PLANS AND CONTACTS

A. Injury Contingency Plan

- 1) In the event injuries occur in connection with a PGV operation, specific and immediate attention will be given to proper transportation to a medical facility.

**Ambulance and/or Paramedics
911**

**Hilo Hospital
(808) 974-4729**

B. Blowout Contingency Plan (Also see Appendix G for detailed Blowout Plans)

Blowout-prevention equipment (BOPE) will be kept in operating condition and tested in compliance with Hawaii regulations and industry standards. Standard kick and blowout drills will be conducted on BOPE before the spud and periodically after spud. These drills will be noted on the tower sheets.

In addition, cold water and barite will be stored at the well site for use in killing the well in case of an emergency. In the event of an emergency, such as a blowout, immediate efforts will be taken to shut surface valves and blowout-preventer system.

If the means to shut-in or control the flow from the well is lost, the Drilling Supervisor is to initiate appropriate control procedures, as follows:

- 1) Arrange for any injured persons to be taken by the fastest transportation available to the nearest medical facility, as shown in the Injury Contingency Plan.
- 2) Secure and maintain control of access roads to the area to eliminate entry of unauthorized personnel.
- 3) Contact the Project Manager and advise of the situation. The Drilling Supervisor will follow the same procedures stated in the Spill or Discharge Plan.
- 4) Initiate any further or supplemental steps that may be necessary or advisable, based on consultation with the Project Manager.
- 5) Be certain that all safety practices and procedures are being followed and that all members of the drilling crew are performing their assigned duties correctly.
- 6) Attempt to control the well at the rig site with rig personnel and supervisors.
- 7) If fluid flow is of an uncontained nature, attempt containment with required equipment by constructing sumps and/or dikes as rapidly as possible and as needed.
- 8) Attempt to construct and/or fabricate and install any wellhead facilities required to contain fluid flow at the well or casing head.
- 9) Maintain a continuing inspection of the pad area immediately around the well site subject to erosion that may cause failure of the drilling rig structure. Take necessary

steps to avert areas of possible erosion by excavation and rebuilding of the area as necessary.

- 10) Following complete containment of the well, initiate steps to return the area to its normal state prior to the blowout or fluid flow, such as reseeding with similar and approved vegetation.

C. Fire Contingency Plan

- 1) Any small fires which occur around the well pad during drilling and/or testing operations should be able to be controlled by rig personnel utilizing on-site firefighting equipment.
- 2) A roster of emergency phone numbers will be available on-site so that the appropriate firefighting agency can be contacted in case of a fire.

D. Spill or Discharge Contingency Plan

- 1) Potential Sources of Accidental Spills or Discharges
 - b) Geothermal Fluid: Accidental geothermal fluid spills or discharges are very unlikely because the hole will be cased and blowout prevention equipment will be utilized. However, accidental discharges or spills could result from a loss of well control (blowout).
 - c) Drilling Muds: Muds are a mixture of water, non-toxic chemicals and solid particles used in the drilling operations to lubricate and cool the bit in the hole, to carry cuttings out of the hole, to maintain the hole condition and to control formation pressure. Drilling muds are prepared and stored in metal tanks at the drilling site. Waste drilling mud and cuttings are discharged into the reserve pit, which is open and is adequately sized to hold the volume necessary for the operation. Accidental discharges of drilling mud are unlikely, but could occur by:
 - (1) Overflow of the reserve pit.
 - (2) Reserve pit wall seepage or wall failure.
 - (3) Discharge from equipment failure on location.
 - (4) Shallow lost circulation channeling to the surface.
 - d) Lubricating or Fuel Oils and Petroleum Products: A discharge of this type would probably be very small and be from equipment used in the field. Potential locations for accidental spills are:
 - (1) Drilling equipment and machinery at and around the drilling location.
 - (2) Other miscellaneous equipment and machinery at well site and roads.
 - e) Construction/Maintenance Debris: Typically, a minor consideration, one which is usually able to be cleaned up on the job. Potential locations are the same as for lubricating or oils listed above.
- 2) Plan for Cleanup and Abatement

In the event of discharge of formation fluids, drilling muds, petroleum products or construction debris, the person responsible for the operation will make an immediate investigation, then contact the Drilling Supervisor and advise him of the spill. The Drilling Supervisor will in turn call out equipment, regulate field operations, or do other work as applicable for control and clean-up of the spill, as follows:

- a) Action - Small, Containable Spill: If the spill is small (i.e., less than 250 gallons) and easily containable without endangering the watershed, the Drilling Supervisor will direct and supervise complete clean-up and return to normal operations.
- b) Action - Large or Uncontainable Spill: If the spill is larger than 250 gallons, or is not easily contained, or endangers, or has entered the watershed, the Drilling Supervisor will proceed to take necessary action to curtail, contain and clean up the spill, as above, and notify personnel as listed below.
- c) Notification
 - (1) The Drilling Supervisor will, as quickly as practicable:
 - Call out contractor(s), as required.
 - Notify the PGV Project Manager.
 - Notify the local law enforcement agencies if the public safety is threatened.
 - Advise local population and affected property owners if spill affects residents or property.
- d) Specific Procedures
 - (1) For geothermal fluid spills:
 - Contain spillage with dikes if possible and haul to disposal site by vacuum or water trucks or dispose of in a manner acceptable to the DLNR.
 - (2) For drilling mud:
 - Repair sump or contain with dikes. Haul liquid to another sump, available tanks or approved disposal site.
 - (3) For petroleum products:
 - Contain spill with available manpower. Use absorbents and dispose of same in approved disposal area.

For (1) through (3) above, PGV will have the source of spill repaired at the earliest practical time and continue working crews and equipment on cleanup until all concerned agencies are satisfied.

- e) Confirm telephone notification to agencies and regulatory bodies. Telephone notification shall be confirmed by the PGV Project Manager in writing within two weeks of telephone notification. Written confirmation will contain:
 - (1) Reason for the discharge or spillage.
 - (2) Duration and volume of discharge or spillage.
 - (3) Steps taken to correct problem.

(4) Steps taken to prevent recurrence of problem.

E. Hazardous Gas Contingency Plan

- 1) There is a possibility of encountering hazardous non-condensable gases while drilling and testing. The three main gases expected in this area are steam, hydrogen sulfide (H₂S), and carbon dioxide (CO₂).
- 2) The effectiveness of this plan is dependent upon the cooperation and effort of each person who enters the site during drilling or testing operations. Each person must know their responsibilities under stressful emergency operating conditions. All personnel must see that their safety equipment is stored and functional in addition to the location and operation of safety equipment.
- 3) All personnel will be trained in warning signs, signals, first aid, and responsibilities in case of hazardous gases. The site will have two briefing areas positions such that one is upwind from the well and containment basin at all times. Before drilling or testing commences, all personnel will be advised of escape routes. Weekly drills will be conducted.
- 4) All vehicles will be parked with the front towards the exit road. A normal-size first-aid kit, stokes litter, wind-direction apparatus, and portable hand-held H₂S and CO₂ detectors will be available on the location. There will also be H₂S-scavenger chemicals on the location for treating the mud. Warning signs will be posted on the access road to the location.
- 5) Steam is hot water in the gas form. It causes burns to the skin. It is possible that steam temperatures may exceed 300°F during flow tests. All personnel must stay away and downwind from venting steam. Note: liquid phase water as hot as 220°F may be present in the testing tanks. If a person receives a burn injury, remove them from the site and cool the burned area on their skin. Transport them to the hospital.
- 6) H₂S is a colorless gas with a rotten egg odor in concentrations under 100 ppm. Above a concentration of 100 ppm, H₂S will cause health problems including death (see Table 1, below). Above a H₂S concentration of 1000 ppm, death is instantaneous. H₂S is heavier than air and will accumulate in low spots. At high concentrations, H₂S is combustible. Automatic H₂S detectors are stationed around the rig. At a 5 ppm concentration, a red light will flash. At this concentration, workers can continue their jobs for 8 hours. At a concentration above 10 ppm, a red light will flash and a warning horn sound. All personnel will immediately assemble at the upwind briefing area (except for the driller who will shut the well in while using the proper protective equipment; the driller will then travel to the briefing area). Remember: at concentrations above 100 ppm, personnel cannot smell H₂S. Hand-held detectors will be utilized to determine the H₂S concentration. Depending on the measured concentration, the Company Drilling Supervisor will assign duties.
- 7) CO₂ is a colorless odorless gas. At concentrations above 50,000 ppm personnel risk affliction. Exposure to concentrations above 80,000 ppm (8%) causes loss of consciousness. The same procedure should be utilized as the H₂S procedure.

- 8) If a person becomes unconsciousness due to a hazardous gas, do not attempt to remove him without proper protective equipment. You May Also Become A Victim. Do not attempt a rescue without proper protective equipment. If you have the proper protective equipment, move the victim to a safe area. If the victim has been affected by H₂S or CO₂, apply artificial respiration until the paramedics or onsite medic arrives. Even if the symptoms pass, transport the victim to a hospital and place him under the care of a doctor.

- 9) After a hazardous gas has been detected, operations will proceed as follows:

a) **Condition – POTENTIAL DANGER**

H₂S concentration <10 ppm

CO₂ concentration <5,000 ppm

STEAM >150°F

All personnel will be immediately notified of the potential danger. Routine checking of the drilling fluid and monitoring equipment will alert mud loggers of possible danger. The mud loggers will immediately notify the Project Manager, Company Drilling Supervisor, Tool Pusher, Driller, Test Supervisor, and Mud Engineer. These personnel will immediately notify their crew members. All safety equipment, monitors, and alarms will be checked for correct operating conditions. A review of the emergency program and drills will be conducted before drilling continues.

b) **Condition – MODERATE DANGER**

H₂S concentration 10 ppm to 20 ppm

CO₂ concentration 5,000 ppm to 50,000 ppm

STEAM >190°F

All personnel will be immediately notified of the danger. The mud loggers will immediately notify the Project Manager, Company Drilling Supervisor, Tool Pusher, Driller, Test Supervisor, and Mud Engineer. These personnel will immediately notify their crew members. The Driller will shut in the well if H₂S concentration exceeds 10-ppm. All personnel will meet at the briefing site. Selected personnel will take steps to locate the source of the hazardous gas. Drilling will not proceed until the gas is controlled. All nonessential personnel will be sent upwind and out of the potential danger zone. Gas concentrations around the well will be verified with hand-held gas detectors. Access to the site will be limited to authorized personnel only. Warning signs will be posted.

c) **Condition – EXTREME DANGER**

H₂S concentration >20 ppm

CO₂ concentration >50,000 ppm

STEAM >200°F

All personnel will be immediately notified of the extreme danger by a honking horn. All personnel will immediately put on their protective gear. The mud loggers will immediately notify the Project Manager, Company Drilling Supervisor, Tool Pusher,



Driller, Test Supervisor, and Mud Engineer. These personnel will immediately notify their crew members. The Driller will shut in the well. All personnel will meet at the upwind briefing site for evacuation. The Drilling Supervisor will assess the situation, outline a control program, and assign duties to control the situation. The proper agencies will be notified. Drilling will not proceed until the gas is controlled. All nonessential personnel will be sent upwind and out of the potential danger zone. Access to the site will be limited to authorized personnel wearing protective equipment. Warning signs will be posted to limit access to the site. If the gas cannot be controlled, the Emergency Plan will be initialized.

TABLE 1: PHYSICAL EFFECTS OF HYDROGEN SULFIDE

CONCENTRATION (ppm)	EXPOSURE TIME		
	0-2 MINUTES	15-30 MINUTES	30-60 MINUTES
10-20	Rotten-egg smell	Detectable	Maximum 8-hour exposure with protective mask
100	Coughing, loss of smell	Eye pain and sleepiness	Throat and eye irritation
450	Eye irritation	Respiration difficult	Serious respiratory disturbance
1000	Unconsciousness	Death	Death



Emergency Personnel and Telephone Numbers

Fire **911**
 Pahoia Fire (808) 965-2708

Law Enforcement **911**
 Pahoia Police (808) 935-3311
 (808) 966-7432

Hospital
 Hilo (808) 974-4729

Company Representative
 Ormat Nevada Inc. (PGV affiliate) (775)-356-9029 (office)
 Mike Kaleikini (Senior Director, Hawai'i Affairs) (808) 936 8161 (cell)

PGV (Ormat) Project Managers

Paul Spielman (Chief Drilling Engineer) (775) 843-3901 (cell)
 James Tennison (Director, Drilling Operations) (760) 550 3459 (cell)
 Jesse Carranza (Drilling Operations Manager) (775) 327-5406 x 42121
 (760) 791-3771 (cell)
 Zach Cesa (Senior Drilling Engineer) (775) 225-2288 (cell)
 Jordan Hara (PGV Plant Manager) (808) 965-6233 (office)
 (808) 494-8882 (cell)
 Puna Control Room (808) 965-2832
 (808) 938 0907 (cell)

Hawaii Department of Land and Resources (DLNR)

Eric Tanaka (808) 961-9588 (office)

APPENDIX G

BLOWOUT PREVENTION AND ACTION PLANS

To Be Posted In Doghouse

5 PREVENTION PLAN

- 1) Fill drill pipe before attaching a circulating head or Kelly and re-establishing circulation
- 2) Pull drill pipe from the well at a speed which does not induce the swabbing of fluid from the well or a reduction of down-hole pressures to less than static formation-fluid pressures.
- 3) Fill well with liquid when pulling the drill string from the well
- 4) Cool the drilling fluid adequately prior to circulating down the drill string
- 5) Pump at an adequate rate to cool the well
- 6) Refrain from pumping a drilling fluid that contains air or gas
- 7) Use a drilling fluid with adequate density to give down-hole pressures in the hole which are more than reservoir fluid pressures at the same depth (that is, drilling in an over-balanced condition).
- 8) Leave hole or part of the hole filled with fluid which has sufficient density and gel strength to avoid becoming gas cut over a period of time. (for example, a pilot hole during the period required to open the full length of the pilot hole to the desired diameter).
- 9) Reduce the rate of penetration to allow gas or heat to be circulated out when drilling through softer formations which may contain gas or high-temperature fluids.
- 10) Pump water to the annulus outside the drill string when drilling without fluid returns.
- 11) Circulate drilling fluid in stages when running drill string into a hot well to remove heat from the well.
- 12) Maintain a kill sheet with slow and fast pumping pressure readings.

BLOWOUT ACTION PLAN *To Be Posted In Doghouse*

A. INDICATIONS OF A BLOWOUT

- 1) Change in the total volume of drilling fluid.
- 2) Signs of formation gas in the drilling returns.
- 3) Increase in the temperature of the drilling fluids.
- 4) Increase in the flow rate of the drilling fluid returns.
- 5) Rapid increase in penetration rate or pumping pressure, or a drilling break (where the hole is advanced rapidly with little or no weight on the bit).
- 6) Loss of circulation. Note: When drilling without returns, a greater loss circulation may be indicated by a rapid loss of pumping pressure.
- 7) An apparent loss of drill-string weight while drilling, which is inconsistent with the rate of feed of the drill string into the well. Note: An influx of hot fluids into the well will cause the drill string to expand, resulting in an increase in the weight on the bit.
- 8) Contamination of the drilling fluids as indicated by a reduction in density or an increase in dissolved solids.

B. GEOTHERMAL KILL PROCEDURES

While drilling a geothermal well, the following procedures should be followed in the event that a kick is possible or is occurring.

- 1) If there is drill string on bottom, pull off bottom to avoid becoming stuck.
- 2) Ensure that the choke line is open, and close an appropriate BOP (that is, blind rams if there is no drill string in the well, pipe rams if the rams are opposite drill pipe, or annular preventer if neither apply).
- 3) Pump cold water or drilling fluid to fill and cool the well. Note: If the drill string is in the well, pumping down the drill string via the Kelly or a circulating head is more effective than pumping down the annulus, but pumping down both may be most effective.
- 4) Control the well head pressure by gradually opening or closing the choke line while pumping caustic to abate H₂S. Note: The wellhead pressure should be limited so as to not exceed the pressure rating of any wellhead component (including casing), and also not to exceed a pressure which is likely to cause breakdown of the formation below the shoe of the deepest cemented casing. Conversely, allowing the wellhead pressure to drop too rapidly to a low value will allow further influx of gas and heat and may induce hole collapse.
- 5) If pumping of cold water or drilling fluid does not cool and control the well flow, then proceed to follow the steps in the Driller's Methods, preferred, (below), or Wait-and-Weight method at Drilling Engineer's discretion.



- 6) If a kick is observed while running casing and cementing, install a good-night valve and close the annular preventer.
- 7) If well starts to flow while running slotted liner, install good-night valve, move liner to put blank section of pipe in annular, and close annular.”
- 8) If a kick occurs when drilling below the intermediate casing (16”), maintain pressure at the shoe (± 2200 feet) below 0.65 psi/ft gradient by relieving pressure through choke or diverter line. Pump heavy mud to increase pressure gradient between shoe and high-pressure zone so surface pressure can be reduced zero with pressure at shoe below 0.65 psi/ft gradient.

Note: Fluids in a geothermal well (including drilling fluids) will be heated to temperatures significantly above 212°F (100°C). When the pressure on such hot fluids reduces, the water in the fluid will start boiling to steam. The steam will reduce the density of the fluid column in the well causing further reduction in down-hole pressures and resulting in boiling additional portions of the liquid column. Such boiling can be self-sustaining and can accelerate until boiling occurs over most of or all of the well depth. This phenomenon is distinctly different from the rising, expanding gas bubble considered as the basis for the kick control in oil and gas drilling and conventional BOP-operating procedures.

C. WAIT-AND-WEIGHT METHOD (DRILLING ENGINEER’S DISCRETION)

- 1) The hole is to be kept full of drilling or completion fluids at all times unless this becomes impossible due to lost circulation.
- 2) Before starting out of hole with drill pipe or tubing, circulate off bottom until mud is properly conditioned.
- 3) Close and open pipe rams once per day and log on tower sheet. Pressure test BOPE prior to drilling out of casing shoes and coincident with casing test. Log results on blowout preventer check list.
- 4) Close blind rams when out of hole and log on tower sheet.
- 5) Fill hole at 5-stand intervals or less while pulling drill pipe out of hole. Count pump strokes or use chart attached to the pit volume indicator to determine the volume required to fill the hole.
- 6) Watch pit flow or pit level indicator when running in the hole to ensure that the volume of mud displaced by the drill pipe is not exceeded.
- 7) The drill pipe will be run in the hole to the shoe of the casing and a TIW valve will be installed to perform any of the following operations:
 - a) Slip or cut drilling line.
 - b) Repair equipment (if possible).
 - c) Any foreseen delay.



- 8) Record reduced circulating pressure at 30 strokes per minute (SPM) or other suitable kick-control pump rate daily and after each bit change.
- 9) An approved float-sub and full-opening safety (TIW) valve with wrench must be immediately available on the rig floor.
- 10) A blowout-prevention drill will be conducted by the rig tool pusher under the supervision of the Drilling Supervisor for each drilling crew to ensure that each person is properly trained to carry out emergency procedures. Assign kick-control duties in advance for mud mixing assigned to floor man, operating pumps assigned to derrick man, etc.
- 11) At first indication of gain in pit level (or other sign of possible blowout), the driller will immediately do what is necessary to control the well. In most cases, this action should be:

While Drilling:

- a) Pull kelly up out of rotary table and stop pumps.
- b) Open valve(s) on choke line.
- c) Close the blowout preventer and gradually re-close choke line.
- d) Record shut-in drill-pipe pressure (Pdp) and casing pressure (Pcg). Maximum allowable casing pressure is dependent on casing depth and burst rating. Allowable pressure for each string is to be posted and noted in driller's instructions and on well-control data sheet.

Inform the Drilling Supervisor as soon as possible and proceed with appropriate kick-control measures as follows in Step 12.

While Tripping:

- a) Install full-opening safety valve.
 - b) Open choke-line valve(s).
 - c) Close safety valve.
 - d) Close blowout preventer and gradually re-close choke-line valve(s).
 - e) Record shut-in drill-pipe pressure and casing pressure.
 - f) Maximum allowable casing pressure is dependent on casing depth, mud weight and burst rating.
 - g) Inform the Drilling Supervisor. Run drill string in hole as far as practical after first installing safety valve and/or float sub and re-opening it, and/or proceed with appropriate kick-control measures as follows in Step 12.
- 12) Calculate and mix mud of weight necessary to keep well under control using the well-control worksheet and attached monograph. Mud weight increase in lb./gallon =

$$\frac{\text{Pdp}}{\text{Drill string depth (ft.)} \times 0.052} + 0.4 \text{ lb./gallon}$$

Where Pdp = shut-in drill pipe pressure in psig.



- 13) When sufficient volume of proper-weight mud has been prepared, start pumping increased-weight mud down drill pipe at constant kick-control SPM, which will lower circulating pressure gradually from P_i (initial drill-pipe circulating pressure, as calculated on the well-control worksheet) to P_f (final drill-pipe circulating pressure) when drill pipe is filled with weighted mud. Thereafter, hold drill pipe pressure constant at P_f by adjusting choke until proper-weight mud returns to surface.
- 14) When proper-weight mud returns to surface, stop pumps, release any remaining pressure on casing, and check for additional kick before returning to normal operations.
- 15) As a last resort to kill well: drill new directional hole.

D. DRILLER'S METHOD (PREFERRED)

- 1) The hole is to be kept full of drilling or completion fluids at all times unless this becomes impossible due to lost circulation.
- 2) Before starting out of hole with drill pipe or tubing, circulate off bottom until mud is properly conditioned.
- 3) Close and open pipe rams once per day and log on tower sheet. Pressure-test BOPE prior to drilling out of casing shoes and coincident with casing test. Log results on tower sheet.
- 4) Close blind rams when out of hole and log on tower sheet.
- 5) Fill hole at 5-stand intervals or less while pulling drill pipe out of hole. Count pump strokes or use chart attached to the pit-volume indicator to determine the volume required to fill the hole.
- 6) Watch pit flow or pit-level indicator when running in the hole to ensure that the volume of mud displaced by the drill string is not exceeded.
- 7) The drill pipe will be run in the hole to the shoe of the casing and a full-opening safety valve will be installed to perform any of the following operations:
 - a) Slip or cut drilling line.
 - b) Repair equipment (if possible).
 - c) Any foreseen delay.
- 8) Record on the tower sheet the reduced circulating pressure at 30 strokes per minute (SPM) or other suitable kick-control pump rate daily and after each bit change.
- 9) An approved float-sub and full-opening safety (TIW) valve with wrench must be immediately available on the rig floor.
- 10) A blowout-prevention drill will be conducted by the rig tool pusher and observed by the Drilling Supervisor for each drilling crew to ensure that each person is properly trained to carry out emergency procedures. Assign kick-control duties in advance: for example, mud mixing assigned to floor man, operating pumps assigned to derrick man, etc.
- 11) At first indication of gain in pit level (or other sign of possible blowout), the driller will immediately do what is necessary to control the well. In most cases, this action should be:



Shut-In Procedure While Drilling:

- a) Pull kelly above the rotary table and stop pumps.
- b) Check the well for flow.
- c) Close the blowout preventer and shut the well in completely.
- d) Record pit level, shut-in drill pipe pressure (P_{sidp}) and shut-in casing pressure (P_{sig}).
- e) Inform the Drilling Supervisor as soon as possible and proceed with appropriate kick-control measures as follows.

Shut-in Procedure While Tripping:

- a) Set slips with tool joint in rotary table.
 - b) Install full-opening safety valve.
 - c) Close safety valve.
 - d) Close blowout preventer.
 - e) Install the kelly.
 - f) Record shut-in drill-pipe pressure and casing pressure.
 - g) Inform the Drilling Supervisor.
- 12) Run drill string in hole as far as practical after first installing safety (TIW) valve and/or float-sub and re-opening it, and/or proceed with appropriate kick-control measures as follows.



E. KICK-CONTROL MEASURES FOR DRILLER'S METHOD

First Circulation

- 1) Select a pump speed for the kill operation. This will usually be the previously recorded slow pump rate. It is important to maintain the pump at a constant stroke-per-minute (SPM) value throughout the kill operation.
- 2) Start the pump and open the choke to maintain the casing pressure (Pcg) constant as the pump is brought up to the desired SPM value ("kill speed"). Once the kill speed is reached, observe the new drill-pipe pressure (Pdp). Record the drill-pipe pressure.
- 3) Pump one full circulating volume at constant SPM value while operating the choke to maintain the drill-pipe pressure constant.
- 4) Stop the pump and shut the choke. At this point the new shut-in casing pressure and the shut-in drill-pipe pressure should be equal. Record these pressures. If a drill-pipe float is making it difficult to obtain drill-pipe pressure readings, the new shut-in casing pressure may be used in the calculation below.

Second Circulation

- 1) Calculate the kill-weight mud density in lb./gal.

$$\text{New Mud Weight} = \text{Current Mud Weight} + \frac{\text{Drill-Pipe Pressure}}{0.052 * \text{TVD}}$$

where TVD = true vertical depth (in feet) at bottom of hole. A trip margin may be added if desired, but management approval is required for a trip margin in excess of 0.2 ppg.

- 2) Start the pump, bringing it up to the kill speed, and operate the choke as necessary to maintain the casing pressure constant. Continue operating the choke to keep the casing pressure constant until one drill-string volume of kill-weight mud has been pumped.
- 3) After pumping one drill-string volume of the kill-weight mud, maintain the pump speed constant and record the circulating drill-pipe pressure.
- 4) Maintain the pump speed constant and operate the choke so as to maintain the drill-pipe pressure constant until kill-weight mud returns are measured at the surface.
- 5) Stop the pump and check for flow.

APPENDIX H

WELDING PROCEDURE FOR 16-in. CASING HEAD

This welding procedure uses the API recommendations for field welding a Slip-On-Weld (SOW) casing head.

1. Cut off existing casing at depth specified by Drilling Supervisor.
2. Grind and clean the area to be welded in the casing and in the interior of the SOW portion of the casing head.
3. Open the test ports on the new casing head. Position and level-up casing head on top of casing.
4. Allow 1.5 mm of space between the slip-on portion of the casing head and the top of the casing, to allow for expansion.
5. Pre-heat casing and casing head to 350°F. Use a pre-heating torch from a distance of approximately 5 to 7.5 cm on either side of the weld location. Use heat-sensitive crayons to test the temperature both inside and outside of the casing and casing head. Special attention must be given to the pre-heating operation of the thick body of the casing head., to ensure proper heating and expansion with respect to the thinner casing.
6. Use a 3-mm (1/8-in.) E-6010, 5P or 7010G electrode for the root pass. Weld approximately 10-cm long bead, and then go diametrically to the opposite side and repeat. Move 90° and weld another portion and again move diametrically opposite. Repeat until the entire first pass has been completed.
7. Clean out the weld slag before welding the second pass.
8. The second pass and the succeeding passes should be made with a 3-mm (1/8-in.) minimum, 4-mm (5/32-in.) maximum 7018B21 electrode. The pass shall be continuous, leaving stringer beads with good penetration. Low-hydrogen electrodes must not be exposed to the atmosphere until ready to be used. If accidentally exposed, they must be dried for 1 to 2 hours at 480 to 575°F before use. Open cans must be stored inside a rod oven.
9. During welding, check casing and casing-head temperatures. Re-heat and maintain temperature to specified range of 248 to 302°F. Do not allow temperature to rise above 572°F during inter-pass welding. Use heat-sensitive crayons to check temperature of the metal elements.
10. Balance welding groove with several (at least three) continuous passes (without back-stepping or lacing), using a low-hydrogen electrode not thicker than 5-mm (3/16-in.). All new passes must be cleaned out of slag before applying the next pass. Inter-pass temperature must be kept below 572°F.
11. Care must be taken that the welding cable is properly grounded to the casing or casing head. The ground wire must be firmly clamped to the casing or casing head. Avoid sparking from bad contact. This could result in hard spots, beneath which incipient cracks could later develop.
12. Re-heat the casing and casing head to 445°F.

13. Repeat the procedure, steps 4 to 7 for welding of the inside portion. Balance the welding groove with one pass of continuous welding, using a thick 5-mm (3/16-in.), low-hydrogen electrode.
14. Wrap elements in an insulating blanket. Stress-relieve casing head following a controlled post-weld heat treatment:
15. Heat casing head and the attached casing to 1112°F to 1202°F.
16. Hold up this temperature for a minimum of one hour per-in. of thickness (casing head slip-on portion plus casing) if total thickness is up to 5 cm. For thickness above 5 cm (2-in.), hold temperature for a minimum of 2 hours plus 15 minutes for each additional 25-mm (1-in.) in excess of 5-cm.
17. The cool-down period shall not exceed the rate of 572°F per hour, divided by ½ of the maximum thickness, without exceeding the maximum rate of 572°F per hour.
18. Remove insulating blankets only when the temperature has reached 347°F.
19. Pressure-test through the casing head testing ports with nitrogen.
20. Test at 1000 psig for 15 minutes.
21. Any defects coming from cracks or holes must be removed to sound white metal by grinding. A new weld bead must be deposited, and (if allowed), a new pass must be made above it.
22. Clean up gasket grooves and rings with solvent and install on casing head. Do not grease groove or rings. Nipple up BOPE.



APPENDIX I

RIG SAFETY INSPECTION FORM

Company: _____ Rig Number: _____ Inspection Date: _____

Toolpusher: _____ Driller: _____ Inspection Made by: _____

() If OK
 (-) If not applicable
 (X) If correction is needed.
 Refer to the back for details.

I. DRILL SITE

- a. AUTHORIZED PERSONNEL signs posted
- b. HARD HAT/SAFETY GLASSES signs posted
- c. NO SMOKING / SMOKING areas designated
- d. NO PARKING near rig
- e. H2S controls if applicable
- f. Over head lines flagged 8' above ground
- g. Toilet Facilities provided
- h. Hard hats/safety glasses available for visitors
- i. Toolpusher's trailer (bunk house) grounded
- j. Toolpusher's trailer tied down
- k. Regulatory Safety, etc. Posters posted as required
- l. Employee training records available as needed
- m. Containers properly marked to contents
- n. Company policies posted
- o. Forklift / misc. hoisting & lifting equipment
- p. Bench grinders properly guarded, tool rest adjusted, PPE available, Safety signs posted.

II. DOG HOUSE(S)

- a. Adequate exits, doors installed properly, operate freely
- b. Approved heaters used
- c. Hazard communication/M.S.D.S. on site
- d. First aid kit and facilities
- e. Crew trained in first aid
- f. Emergency phone numbers posted
- g. Outside communications provided
- h. Safety equipment available
- i. Crew wearing hard hats and safety glasses
- j. Crew wearing hard-toed shoes (boots)
- k. Proper clothing worn by crew
- l. No hazardous jewelry worn
- m. NO SMOKING rules observed
- n. Accidents-posted on OSHA or other incident log
- o. Ton miles logged _____
- p. Gas detector fully charged and sensors working
- q. B.O.P. drills, test logged _____
- r. Safety meetings logged _____
- s. Driller or competent person at or near controls
- t. Toolpusher/Rig Manager at rig location
- u. Approved and adequate lighting
- v. General Housekeeping

III. DRILLING FLOOR AREA

- a. Rotary table area
- b. Kelly bushing guard used
- c. Kelly Safety Controls adequate if no guard used
- d. Rotary chain drive guarded
- e. All unused floor holes covered
- f. Lighting
- g. Pipe / collar slips, dies, handles, pins, keepers
- h. Racking floor area
- i. Vee door gate provided - in place
- j. Makeup and breakout tongs
- k. Tong snubbing lines, clamps
- l. Tong counter weights (sheave assemblies)
- m. Tong body and jaws condition
- n. Tong safety handle pin secured
- o. Tong dies sharp, keeper used
- p. Air hoist line, guide, guarded
- q. Catheads surface smooth, anti-ropo fouling device
- r. Callinets)
- s. Kelly cock, wrench accessible
- t. Jerk and Spinning chain, headache post
- u. Breakout tong pull back cable, guide rollers
- v. Crown-O-Matic device, operating
- w. Drilling line
- x. Drawworks and overrunning clutch
- y. Driller's controls
- z. Hand tools
- aa. Drawworks Drum Drill Line Anchor secure
- bb. Drawworks Brake Linkage
- cc. Drawworks Guards
- dd. Proper electrical wiring provided as required
- ee. Fire extinguishers properly marked, inspected
- ff. Safety signs posted as needed.
- gg. General housekeeping

IV. STAIRS, WALKWAYS, HANDRAILS, GUARDRAILS

- a. Adequate stairs provided off rig
- b. Stairs level, secure, no obstructions
- c. Adequate handrails provided (stairs)
- d. Stair treads uniform, of non-skid type
- e. Guardrails, mid-rails, toe boards
- f. Handrails used

V. SUBSTRUCTURE

- a. Safety Signs Posted as needed
- b. Approved and adequate lighting
- c. Substructure's beams and braces
- d. All assembly pins in place, secure
- e. Dead line properly anchored

VI. BLOWOUT PREVENTERS

- a. B.O.P. properly installed, tested
- b. Wheels and stems in place
- c. BOP Stack properly stabilized
- d. All hydraulic lines connected, no leaks/damage, & protected
- e. All unused lines capped
- f. Accumulator & Remote Control unit(s) properly located - Unobstructed
- g. Gauges properly located - in good condition
- h. Choke manifold and line, secured
- i. Blooey line used, pilot light used
- j. Approved wiring and lighting in use and adequate lighting
- k. Signage
- l. Scaffolding boards secured and in good condition
- m. Fall protection properly attached under rig floor protected clean
- n. BOP Remote control properly labeled and operating
- o. Fire extinguisher located near BOP Controls area
- p. Housekeeping, drainage

VII. PIPE RACK AREA

- a. Ends of pipe racks chocked
- b. Layers of pipe chocked, spacers used
- c. Pipe racks level, stable
- d. Pipe rack catwalk
- e. Stairs with hand rails provided
- f. Vee door slide, pipe stops used
- g. Pipe lubs and bridles
- h. Derrick stand and ladder
- i. Employees not on top of pipe
- j. Drilling line from anchor to spool elevated off the ground
- k. General housekeeping, lighting

VIII. DERRICK, DERRICK BOARD AREA & CROWN AREA

- a. Derrick ladder - good condition
- b. Derrick climber installed properly - good condition and used
- c. Climbing/Derrick board Safety Harness, safety catch
- d. Safety lines or lanyards used
- e. Derrick emergency escape line
- f. Derrick escape cart on line or escape assembly installed
- g. Pipe fingers and tools secured (finger safety line(s) attached)
- h. Standpipe(s) (mud, air, hydraulic, gas vent) secured
- i. Mud hose snubbed on both ends
- j. Derrick board & Stabbing board fall protection installed
- k. Derrick Board / Stabbing Board - good condition
- l. Derrick properly guyed if applicable
- m. Boom(s) and boom lines
- n. Sheaves & Shackles properly attached to the derrick (safety line(s) / clips attached)
- o. Approved and adequate lighting
- p. Derrick Crown Light operating and in good condition, secure
- q. Crown Saver blocks are in good condition & wrapped with expanded metal
- r. Handrails at crown in good condition.
- s. Derrick, A-frame - pins in place, secured with keepers
- t. Elevators, balls
- u. Traveling Blocks, Top Drive, Swivel
- v. No loose ropes or other items in the derrick.
- w. General housekeeping

IX. MUD PUMP AREA

- a. Rotating Equipment, Drive Belts, Pony Rods guarded
- b. Head and valve covers fully bolted
- c. Shear pin pop-off valve covered/tested
- d. Ends of relief lines secured
- e. Ends of high pressure vibrator hose(s) snubbed
- f. Approved and adequate lighting
- g. Drip pans installed and cleaned as needed.
- h. Tools & supplies stored in proper place.
- i. General housekeeping

X. MUD MIXING AREA

- a. Bagged material properly stacked
- b. Caustic or acids properly stored separate from other materials
- c. Chemical mixing barrel
- d. Adequate personal protective equipment
- e. Signs posted & MSDS in mixing area(s)
- f. Adequate eyewash (shower) available
- g. Adequate ventilation in area
- h. Elevated loading door opening protected
- i. Approved and adequate lighting
- j. General Housekeeping

XI. MUD TANKS AND PITS

- a. Adequate stairs with handrails
- b. Walkways & guardrails in good condition
- c. Walkways free from obstruction/tripping hazards
- d. Gates seal, no leaks in tanks
- e. Adequate ventilation in area
- f. Guardrails provided on crossovers
- g. Approved adequate lighting
- h. Eye protection required warning signs
- i. Shale shaker belt & pulley drive guarded
- j. Desander, desilter, degasser units
- k. Explosive-proof equipment at shale shaker area
- l. Agitator shafts and couplings guarded
- m. Mud guns and jetting hoses secured
- n. General housekeeping

XII. GENERATOR AREA & ENGINE AREA

- a. Generators properly located
- b. All generator moving parts guarded
- c. Generators properly grounded
- d. Cover panels on electrical control boxes
- e. Electrical controls marked - lockout/tagout
- f. HIGH VOLTAGE warning signs used
- g. Insulating mats at electrical panels
- h. All electrical tools grounded
- i. Condition of electrical wiring
- j. Electrical wires properly strung
- k. Unused electrical outlets covered
- l. Air compressors properly guarded
- m. Air storage tanks equipped with pop-off
- n. Hearing Protection Signs Posted
- o. Hearing protection available & utilized
- p. S.C.R. house if available
- q. Lighting
- r. Engine drip pans installed in good condition
- s. General housekeeping

XIII. FUEL STORAGE TANKS

- a. Fuel storage tanks properly located
- b. All storage valves marked as to contents
- c. Discharge nozzles, hoses, valves
- d. Liquefied petroleum gas storage tanks
- e. Piping and fuel lines
- f. Stationary ladders on storage tanks
- g. NO SMOKING signs posted
- h. Tanks labeled as per hazard & contents
- i. Off road use only sign posted as needed
- j. Drip pans installed in good condition
- k. General housekeeping, lighting

XIV. FIRE PROTECTION

- a. Adequate fire extinguishers distributed around the rig and location, not obstructed
- b. Fire extinguishers fully charged, in good condition, current inspection
- c. NO SMOKING Signs posted as needed
- d. No open pit burning
- e. Flammables in U.L. safety cans
- f. Flare area clear of combustibles
- g. Boiler (air heater) and its safety controls
- h. Welding performed safely
- i. Fire Watch Posted
- j. Spark and heat arrester on engines

XV. SLEEPING QUARTERS/BUNK HOUSE

- a. Quarters / Bunk house clean & Orderly
- b. Restroom clean & sanitary, needed supplies available
- c. Smoke/Fire alarms available and working
- d. Food preparation area clean, food and dishes put away
- e. Fire Extinguishers available
- f. Two exits - unobstructed

Unsatisfactory mark requires clarifying comment.



APPENDIX J REPORTING CRITERIA

1. The Project Supervisor shall report to the PGV Manager on the day-to-day operations.
2. Based on past experience at the Puna Geothermal Project, it is imperative that constant supervision of the well be accomplished once the drilling commences. PGV Supervisors will be in charge of all activities on location. PGV Supervisors will report to the PGV Manager.
3. Supervisors will spend sufficient time together at the rig during change-out to exchange information on the current activities. Supervisors will be on the floor, on the pump truck, in the wireline unit, etc. for all critical operations.
4. The Manager will be responsible for engineering programs with input from the Supervisors. The Manager will also advise and assist the Supervisors.
5. Contractor's supervisors will report to the Supervisor on location. They will also be on the floor during all crew changes.
6. Reporting procedures for crews will be the responsibility of the contractor. Drillers will log all rig operations on the IADC daily tower report, including the depths of all work performed. Rig crew will assist service company personnel as directed by the contractor's supervisor. Standard kick and blowout drills should be conducted periodically; these drills should be noted on the tour sheets

APPENDIX K

DLNR RECOMMENDED PRACTICE FOR RUNNING A FORMATION-INTEGRITY TEST (FIT)

The following steps shall be taken in conducting a Formation-Integrity Test (FIT) to assess the ability of the formation around the shoe to withstand a desired minimum pressure and to ensure the mechanical integrity of the well.

1. Each casing depth needs to be specified in the drilling program; however, the actual depth of the casing shoe shall be dictated by the actual well conditions and not by the depth prescribed in the program or by a given length of pipe that is available at the site.
2. The shoe shall be set in competent formation, and the wellsite geologist shall be consulted about the competency of the formation where the shoe is to be properly set.
3. The shoe will be set as close as possible to the bottom of the drilled hole.
4. After cementing, the formation and the casing shoe will be tested, taking in consideration the following parameters:
 - a. The shoe shall be drilled out to a minimum of 1 foot of formation (below any cement), or when the mud returns show 100% formation.
 - b. Other than monitoring the mud returns, the ROP and WOB will be observed while drilling below the shoe, to determine if drilling is occurring in formation or cement.
5. The target pressure for conducting the FIT shall not be greater than the equivalent of a 0.65 psi/ft gradient.
6. The objective of the FIT is to assure that the formation can hold the highest anticipated Equivalent Mud Weight (EMW) for the next hole section, in case of a well-control event.

At any time during the drilling operation, the weakest point of the well would be at the bottom of the last cemented casing shoe. To ensure the best chance at improving the integrity of the well, the strength of the shoe should be a prime safety consideration in the construction of the well.